

CABLE MANAGEMENT SYSTEMS

KDS cable entries
KES cable entries
SAB|SSAB|SABK shielding solutions



Catalogue 08

Contents

Our company	3
<hr/>	
The advantages online	4
<hr/>	
Globally available for you	5
<hr/>	
Catalogues	6
<hr/>	
Product portfolio	8
<hr/>	
KDS-FB Cable entry system for flat cables	10
<hr/>	
KDSClick Modular cable entry system	20
<hr/>	
KDS-FP Flange plates	26
<hr/>	
KDS-KV Separable cable glands	34
<hr/>	
KDS BW Actuating tool	40
<hr/>	
KDS-EMV-SAB Shield-connection rails	41
<hr/>	
Sealing elements for all KDS systems	42
<hr/>	
KES Cable entries	44
<hr/>	
Punching tools	52
<hr/>	
Shield-connection clip	56
<hr/>	



CONTA-CLIP: thinking ahead for connection systems

CONTA-CLIP was founded in 1978. We operate globally as an owner-operated medium-sized company.

Users of electrical and electronic connection systems rely on our reliable products and our many years of industrial and global market expertise.

Our company is now one of the most important manufacturers in the field.

For over 40 years, our components and solutions have been used in various process and industrial automation applications, including: railway technology, materials handling, building automation, air conditioning, mechanical and facility engineering, measurement and control technology, control panel construction, shipbuilding, transformer construction and environmental technology.

Over the years, we have evolved into an innovator that sets the tone with new ideas and creative impulses.

Our employees come from a wide variety of industries and view themselves as true connectivity specialists. They understand the specific problems, requirements and challenges of our customers. This results in communication among equals.

The profits then flow into the development of new products as well as into modern, efficient manufacturing processes.

A high quality standard throughout all departments is our number one priority.

Our top-class products are supported by this interplay between top-class men and machinery. We have also designed our range of services to align with customer needs.

Our products are divided into six categories: CONTA-CONNECT for terminal blocks and accessories, CONTA-ELECTRONICS for electrical and electronic control cabinet components, CONTA-LABEL for marking systems, Cable Management Systems, CONTA-BOX for housings and CONTA-CON for PCB terminal blocks and connectors.

We design customer-specific solutions for electronics, provide completely assembled housings and assemblies as needed, assemble terminal blocks for series production, and quickly handle component labelling tasks.

We greet these challenges with passion and enthusiasm, because we see each customer as our partner.

CONTA-CLIP customer representatives are always ready to offer their support to the customer, because service and helpfulness are rooted deeply in our corporate philosophy.

Advantage online: the CONTA-CLIP Online Catalogue

No matter where you are, as long as you're online you can access our digital catalogue to view our service portfolio and quickly identify suitable solutions for your requirements.

Fast results Use the full-text search, enter an order number or use the convenient "step-by-step" feature search function.

Project planning at a glance: After you've selected the products, all the master data for the materials (sales data, technical data, drawings, connection diagrams, classifications and approvals) are made available as a data sheet or export file.

Detailed inquiries about components can be sent via the shopping cart directly to our headquarters. Upon request, you will receive an e-mailed copy of your inquiry.

Application films: Complex functions be explained easily and clearly with sounds and images.

Printed catalogue: Would you like an offline overview? Please ask for our free printed catalogues.

Industry-specific: You will find the solutions that are relevant for your industry, according to your expertise.

Newsletter: Do you want to stay up to date? Subscribe to our newsletter! Simply register, confirm our authentication e-mail, and you'll be regularly informed about all CONTA-CLIP news.

Discover how the world of CONTA-CLIP and our website can deliver added value to you and your projects!

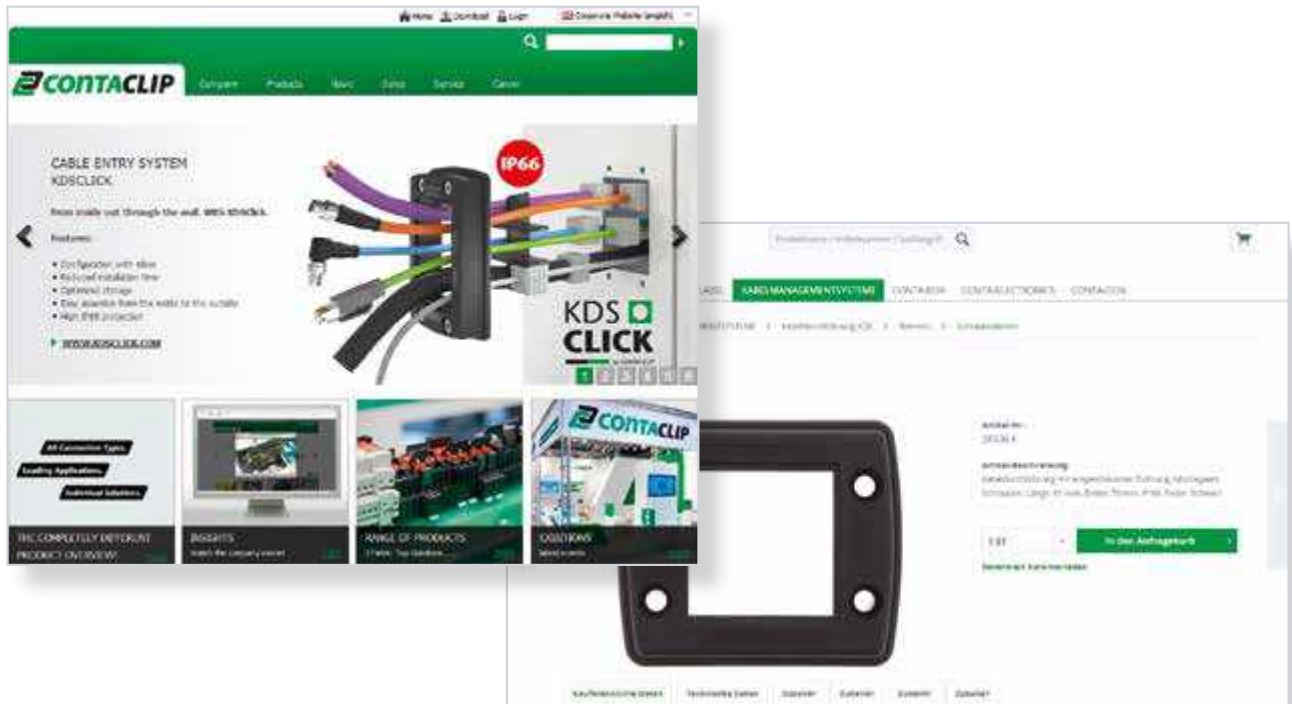

Globally available for you

Are you working abroad? No problem. Our worldwide sales and distribution partners help us to be globally networked and provide on-time reliable deliveries. Simply scan the QR code shown and you'll find out on our website about the sales partner responsible for your country.



Our locations in Africa

Algeria
Morocco
South Africa

Our locations in Asia

Bahrain
China
Hong Kong
India
Israel
Jordan
Malaysia
Oman
Pakistan
Qatar
Saudi Arabia
Singapore
South Korea
Taiwan
Turkey
United Arab Emirates

Our locations in Australia

Australia
New Zealand

Our locations in Europe

Austria
Belarus
Belgium
Bosnia and Herzegovina
Bulgaria
Croatia
Czech Republic
Denmark
Finland
France
Great Britain
Germany
Greece
Hungary
Iceland
Ireland
Italy
Latvia
Netherlands

Norway

Poland
Portugal
Romania
Russia
Serbia
Slovakia
Slovenia
Spain
Sweden
Switzerland
Ukraine

Our locations in North America

Canada
Mexico
United States

Our locations in South America

Bolivia
Brazil
Chile
Ecuador

A complete line of products for your challenges

The CONTA-CLIP Catalogues



01 CONTA-CONNECT

Terminal blocks with Push-in connection system

Our wide range of innovative PRK and FRK terminal series with the Push-in connection system include feed-through terminals, PE terminals, disconnect terminals, fused terminals, multi-level terminals, installation terminals and initiator terminals, for conductor cross-sections from 0.2 mm² to 25 mm².

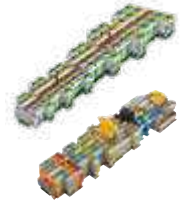

Cat. no. 98070.2

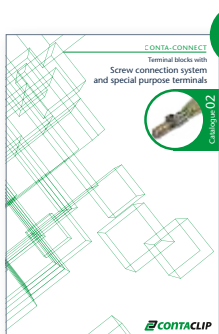

02 CONTA-CONNECT

Terminal blocks with screw connection system and special terminals

Everything for classic wiring with screw connection systems (also for high currents): SRK feed-through and PE terminals, RK high-temperature variants, TK transformer terminals, HSK high-power stud terminals, SVB series screw distributor blocks, and the modular feed-through terminal systems from the SDK series.



Cat. no. 98071.2

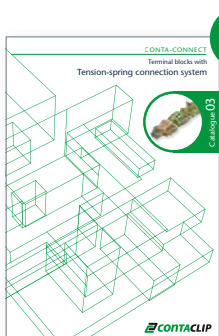

03 CONTA-CONNECT

Terminal blocks with tension-spring connection system

Our versatile line of terminals with tension spring connection systems for conductor cross-sections from 0.2 mm² to 16 mm² includes: the ZRK/ZSL series of feed-through and PE terminals, the double-level ZRKD/ZSLD, the ZIKD three-level terminal blocks, motor-connection terminals, (blade-) disconnect terminals, fused terminals, direct-mount terminals, and initiator/actuator terminals for transmitting positioning, encoder and alert signals.



Cat. no. 98072.2



04 CONTA-CONNECT

Installation materials and other accessories for terminal blocks

Our installation products include cabling ducts, assembly tools, cable glands with metric or PG threads, DIN rails, DIN rail cutters and punching tools. The terminal block accessories include different versions of end stops, wire-end ferrules, and connectors.



Cat. no. 98073.2



05 CONTA-LABEL

Marking components for thermal transfer marking systems

CONTA-CLIP provides the TTPCard thermal-transfer printer and a large selection of PC, PVC and PVCF markers or labels in card format: for professional, permanent labelling of terminals, devices, conductors, cables, facilities and switchgear cabinets.



Cat. no. 98074.2

Our catalogues are available in many languages!

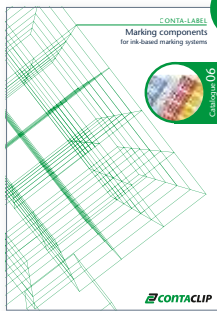

06 CONTA-LABEL

Marking components for ink-based marking systems

The CONTA-LABEL products provide polyamide markers for labelling conductors, cables, devices and facilities with ink print. These markers are available in many shapes and colours: in the classic MC Maxicard format for self-printing with the EMS plotter system EMS or other ink-jet systems, or ready-to-use customized printed in the PMC Pocket-Maxicard format.

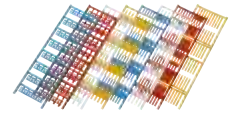

Cat. no. 98075.2

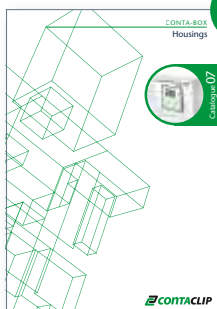

07 CONTA-BOX

Housings

Our wide variety of housings made of polystyrene, polycarbonate, polyester, ABS and aluminium deliver solutions for protecting electronic circuits, integrated devices and terminal blocks. On request, the housings can be provided with extensive processing and assembled with our CONTA-CONNECT, CONTA-ELECTRONICS and CONTA-CON product lines.



Cat. no. 98076.2



08 CABLE MANAGEMENT SYSTEMS

KDS cable entries, KES cable entries, SAB|SSAB|SABK shielding solutions

The KDS and KES cable entries enable a tool-free, IP66-sealed feed-through for unassembled and assembled cables and hoses. The feed-through openings can be adapted at any time to meet your requirements. The SAB shield-connection clips can be used to provide a reliable shield contact with conductor diameters from 3 mm to 35 mm.



Cat. no. 98077.2



09 CONTA-ELECTRONICS

Electrical and electronic cabinet components

Our CONTA-ELECTRONICS products provide active and passive components for the transfer and conversion of analogue and digital signals at the coupling level. This product line includes power supplies, multi-function timing relays, coupling relays, digital switching modules, interface modules, opto-couplers, signal converters, GSM communication modules and much more.



Cat. no. 98078.2

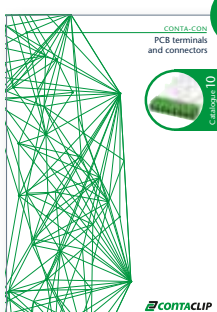

10 CONTA-CON

PCB terminals and connectors

This catalogue presents our wide variety of CONTA-CON PCB terminal blocks and connector systems. The modular components can be configured for any required number of poles; They are available in the wire connection types: wire protection, eccentric, clamping yoke, and (for demanding operating conditions) with tension-spring or Push-in wire termination.

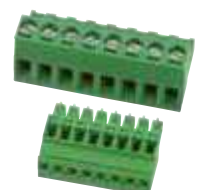

Cat. no. 98079.2

Cable management systems

KDS cable entries

The KDS cable entry system has a modular design consisting of frames, frame inlays and seals. This enables quick and easy dimensioning of feed-through openings for pre-assembled cables – without the use of tools. The system reliably ensures an IP66 seal. Since the diameter and number of frame openings can be adapted at any time without costly dismantling of the frame, switchgear cabinets or machine housings can be uniformly prepared for different purposes using KDS. This results in significantly less costs and warehousing overhead. Our wide range of KDS seals currently includes more than 90 variants and is constantly being expanded.

KES cable entries

The KES cable entries enable unassembled cables or pneumatic hoses to be quickly inserted into switchgear cabinets or housings without using tools. The KES entry plates feature a dimensionally stable, elastomer-encapsulated polyamide frame. In order to insert the required number of cables, the surface membrane is first pierced with a screwdriver. Then, the unassembled cables are easily pushed through. Tapered inlet grommets on the back of the plate provide IP66 sealing and reliable strain relief. With up to 32 cables per plate, the KES achieves a significantly higher packaging density than conventional entry systems.

SAB|SSAB|SABK shielding solutions

The SAB shield-connection clips provides an easy tool-free contact for the cable shield. It is a modular system for mounting to DIN rails, busbars or direct mounting. The system includes shield-connection brackets for cable diameters from 1.5 mm to 18 mm, clamp mounting feet for all attachment types, busbar holders and shield-connection clips with screw or spring contacts. The stripped cable is easily pushed into the SABK shield-connection brackets. The spring force in the bracket then ensures that the shield has a consistently good contact. The large-area shield contact ensures low-impedance discharge resistances, even at high frequencies. The SAB/SSAB shield-connection clips cover a clamping range for cable diameters from 3 mm to 35 mm. This product line also includes busbar rail holders and end supports for mounting to busbars.





KDS-FB
Cable entry system for flat cables

The KDS-FB cable entry system for flat cables provides you with outstanding versatility and saves you time while managing cables, especially for industrial trucks, crane systems and elevator applications.

Page 10



KDSClick
Modular cable entry system

The KDS-SR screw frames are available in 4 different sizes. The inlays make a wide variety of combinations possible.

Page 20



KDS-FP
Flange plates

The KDS-FP flange plates are available in 2 different sizes. The inlays make a wide variety of combinations possible.

Page 26



KDS-KV
Separable cable glands

The KDS-KV separable cable glands are designed for metric break-outs of 20 to 63 mm diameter.

Page 34



KES
Cable entries

The KES cable entry system can be used to insert unassembled cables as well as pneumatic and hydraulic hoses.

Page 44



SAB
Shielding solutions

Our shield-connection clip products provide a modular system for direct installations or DIN-rail mounting.

Page 56

KDS-FB

Cable entry system for flat cables

Fast. Safe. Turning cables inside out!
The KDS-FB cable entry system for flat cables provides you with outstanding versatility and saves you time while managing cables, especially for industrial trucks, crane systems and elevator applications.

The "fish skin" on the seals mechanically surround the inserted flat cable; they ensure optimum tolerance compensation and IP66 protection.

Supported by:



Federal Ministry
for Economic Affairs
and Energy

on the basis of a decision
by the German Bundestag

Attaching the frame

Made from a single mould, the one-piece frame is quick and easy to assemble. It is made of sturdy, glass-fibre reinforced plastic.



Quickly assembled from the inside out

The frame does not need to be disassembled if your requirements change or if you're carrying out service work.



Captive seal

The moulded-in frame gasket eliminates the risk of incorrect assembly (forgotten seal) and speeds up the assembly process.

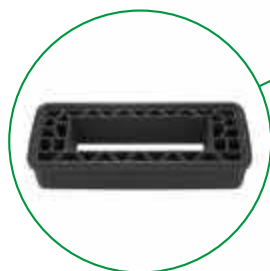

Seals

The seals' conical shape enables them to be easily pressed in so they can seal gaps. To attach them, the seals are pressed from the inside out into the openings. There are currently over 90 different seals that can be used for sealing cables of various diameters and sizes.

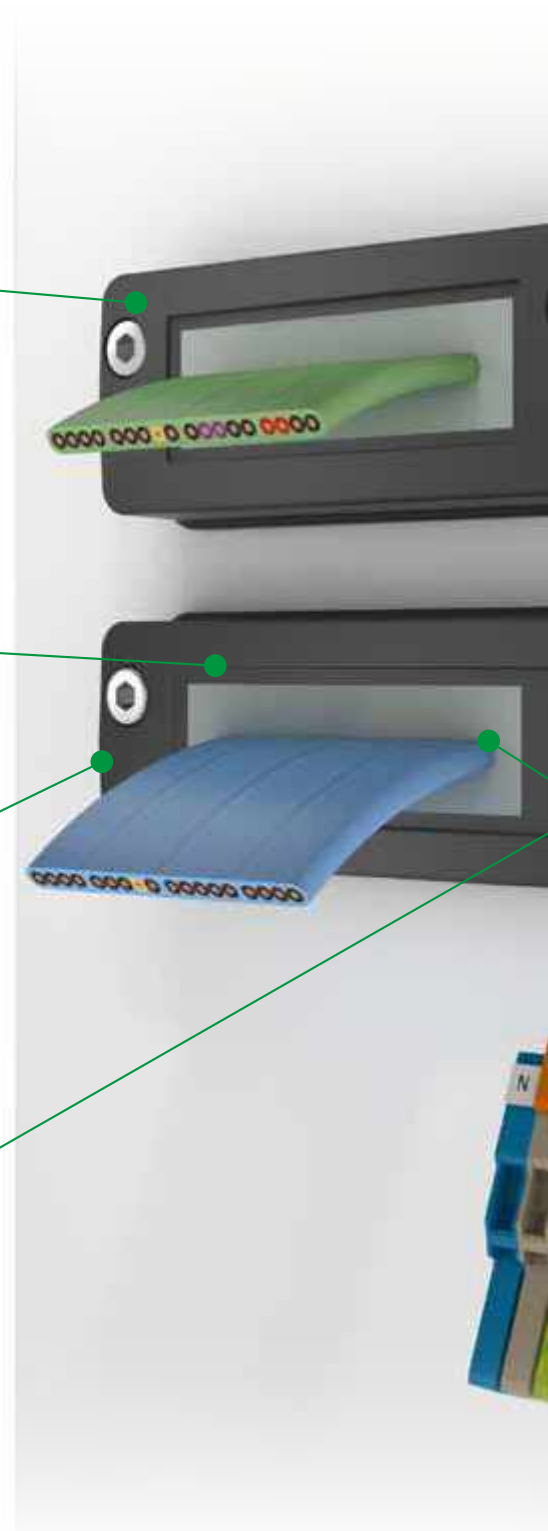
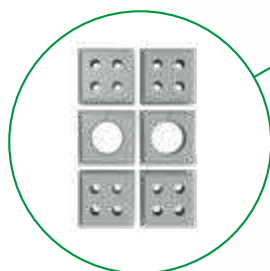



Your advantages

30% less time required for new installations because of the one-piece frame. Modifications, retrofits, service work or the readjustment of cable lengths can be made at any time without disassembling the frame, since the seals are released from the outside inwards by simply pressing in.



Versatile, high-density assemblies are possible

1-way, 2-way, and 4-way seals provide you with excellent versatility for cable management.

IP66



Outstanding IP66 seal

Multi-resistant, tapered seals feature inner and outer sealing gills.

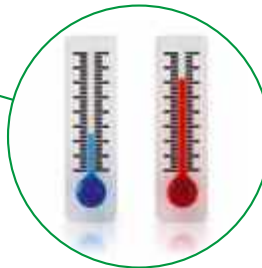

Can be used from $-40\text{ }^{\circ}\text{C}$ to $+120\text{ }^{\circ}\text{C}$

Materials contain no halogen or silicone, suitable for many different applications.

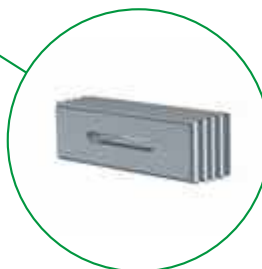

Fish skin

The "fish skin" mechanically surrounds the inserted flat cable; this ensures outstanding tolerance compensation and IP66 protection.

KDS-FB

Cable entry system for flat cables

Frame	KDS-SR-FB1/A	KDS-SR-FB2/A	KDS-SR-FB2/B
			
Diagram	Page 14	Page 14	Page 14
Type / colour	KDS-SR-FB1/A BK	KDS-SR-FB2/A BK	KDS-SR-FB2/B BK
<i>Cat. no.</i>	28700.4	28701.4	28702.4
Qty.	10	10	10
Seals (refer to page 16)			
KDS-DE 20 x 20			1 x
KDS-DE-FB1	1 x		1 x
KDS-DE-FB2		1 x	
KDS-DE-FB3			
KDS-DE-FB4			
Accessories			
Actuating tool (refer to page 40)	KDS BW 1	KDS BW 1	KDS BW 1
<i>Cat. no.</i>	28622.0	28622.0	28622.0
Qty.	1	1	1
Sheet-metal punch (refer to page 54)	BL-VA KDS-FB1	BL-VA KDS-FB2	BL-VA KDS-FB2
<i>Cat. no.</i>	28729.0	28730.0	28730.0
Qty.	1	1	1
Frame	KDS-SR-FB4/A	KDS-SR-FB4/B	KDS-SR-FB4/C
			
Diagram	Page 15	Page 15	Page 15
Type / colour	KDS-SR-FB4/A BK	KDS-SR-FB4/B BK	KDS-SR-FB4/C BK
<i>Cat. no.</i>	28707.4	28708.4	28709.4
Qty.	10	10	10
Seals (refer to page 16)			
KDS-DE 20 x 20		2 x	1 x
KDS-DE-FB1			2 x
KDS-DE-FB2		1 x	
KDS-DE-FB3			
KDS-DE-FB4	1 x		
Accessories			
Actuating tool (refer to page 40)	KDS BW 1	KDS BW 1	KDS BW 1
<i>Cat. no.</i>	28622.0	28622.0	28622.0
Qty.	1	1	1
Sheet-metal punch (refer to page 54)	BL-VA KDS-FB4	BL-VA KDS-FB4	BL-VA KDS-FB4
<i>Cat. no.</i>	28732.0	28732.0	28732.0
Qty.	1	1	1



Features

- Material: polyamide PA 6.6, glass-fibre reinforced | TPE
- Colour: black
- Flammability: UL 94 V-0
- Temperature range: -40 °C to +120 °C
- Halogen-free, silicone-free
- Protection: IP66



Page 15	Page 15	Page 15	Page 15
KDS-SR-FB3/A BK 28703.4	KDS-SR-FB3/B BK 28704.4	KDS-SR-FB3/C BK 28705.4	KDS-SR-FB3/D BK 28706.4
10	10	10	10
	1 x		2 x
	1 x	2 x	1 x
1 x			

KDS BW 1 28622.0	KDS BW 1 28622.0	KDS BW 1 28622.0	KDS BW 1 28622.0
1	1	1	1
BL-VA KDS-FB3 28731.0	BL-VA KDS-FB3 28731.0	BL-VA KDS-FB3 28731.0	BL-VA KDS-FB3 28731.0
1	1	1	1



Page 15	Page 15	Page 15
KDS-SR-FB4/D BK 28710.4	KDS-SR-FB4/E BK 28711.4	KDS-SR-FB4/F BK 28712.4
10	10	10
3 x		5 x
1 x	1 x	
	1 x	

KDS BW 1 28622.0	KDS BW 1 28622.0	KDS BW 1 28622.0
1	1	1
BL-VA KDS-FB4 28732.0	BL-VA KDS-FB4 28732.0	BL-VA KDS-FB4 28732.0
1	1	1

KDS-FB: dimensional drawings / mounting cut-outs

KDS-SR-FB1

Dimension diagram

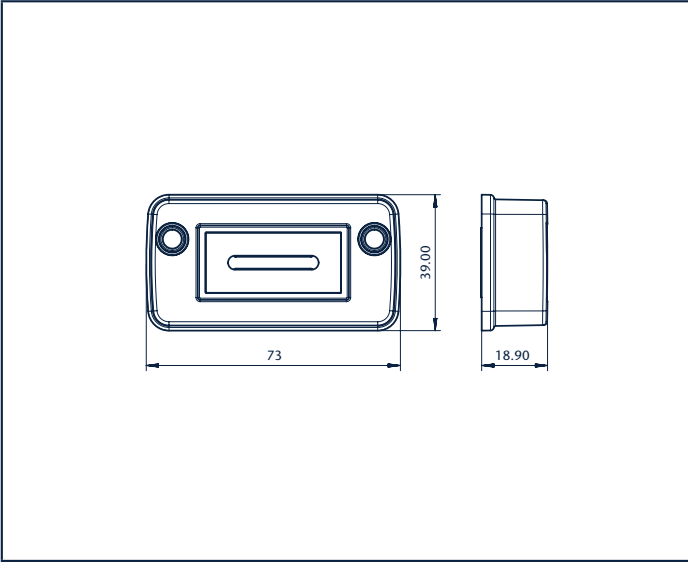

Torque for the frame's mounting screw: 3 Nm

Mounting cut-out

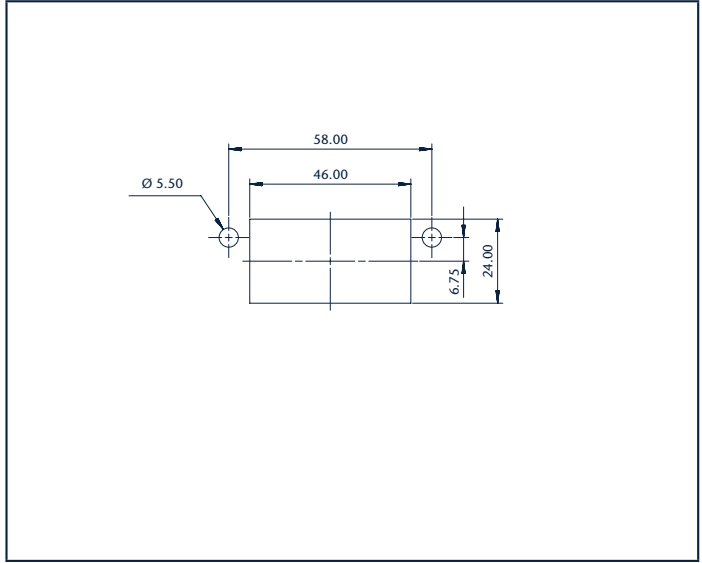

Screw for usage: ISO 4762 / DIN 912

KDS-SR-FB2

Dimension diagram

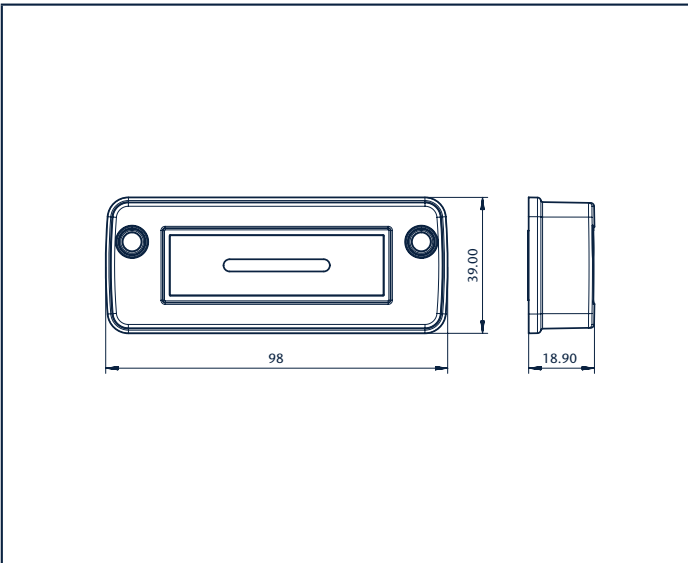

Torque for the frame's mounting screw: 3 Nm

Mounting cut-out

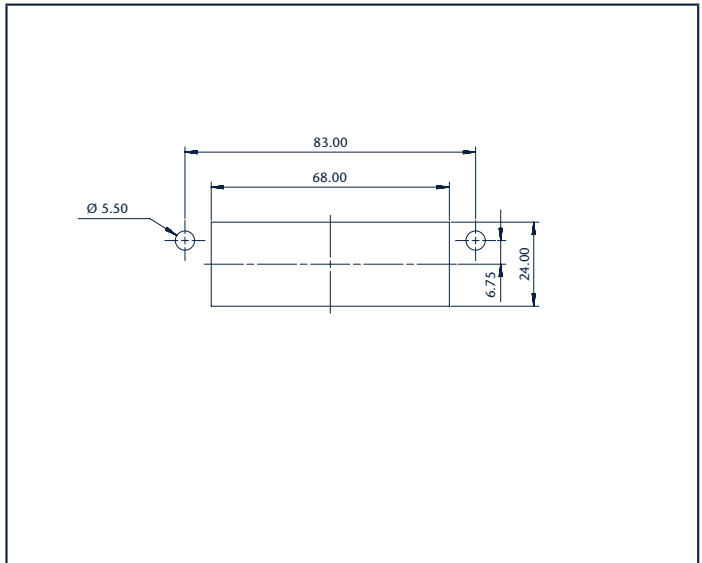

Screw for usage: ISO 4762 / DIN 912

KDS-SR-FB3

Dimension diagram

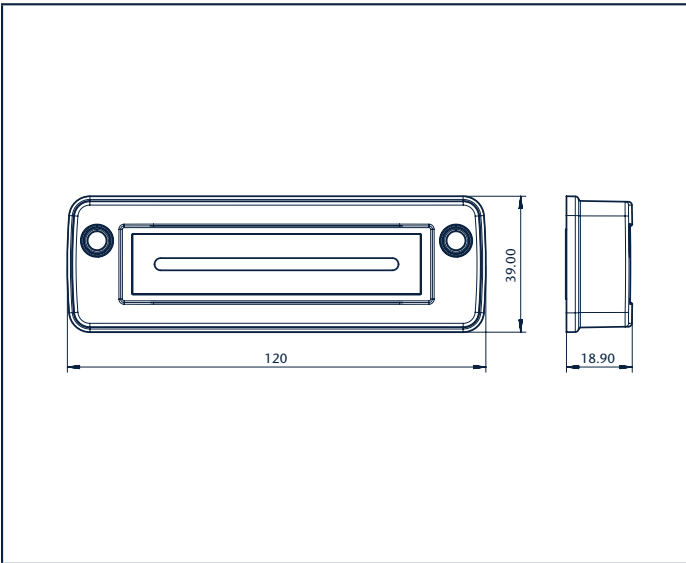

Torque for the frame's mounting screw: 3 Nm

Mounting cut-out

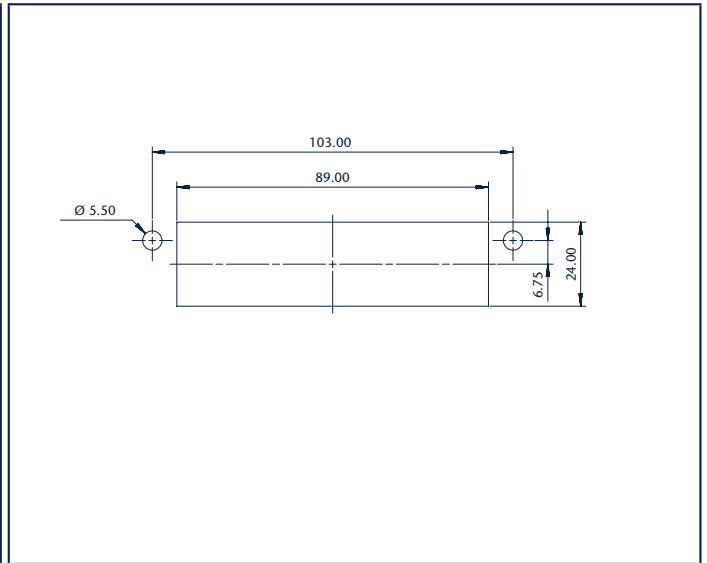

Screw for usage: ISO 4762 / DIN 912

KDS-SR-FB4

Dimension diagram

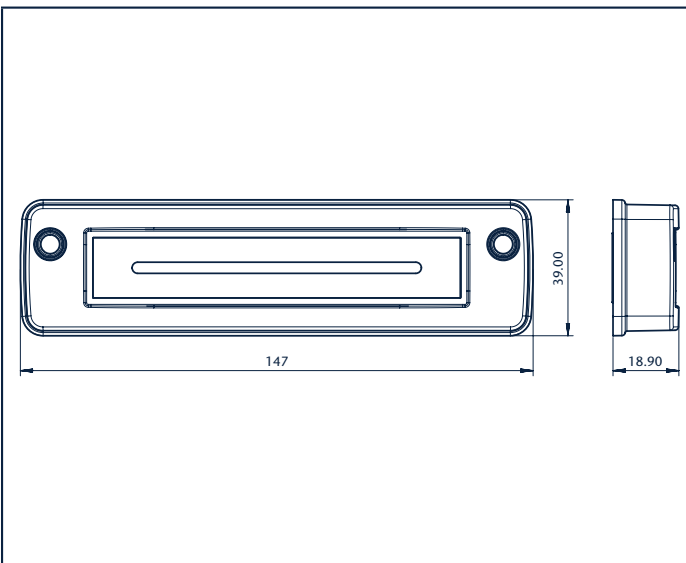

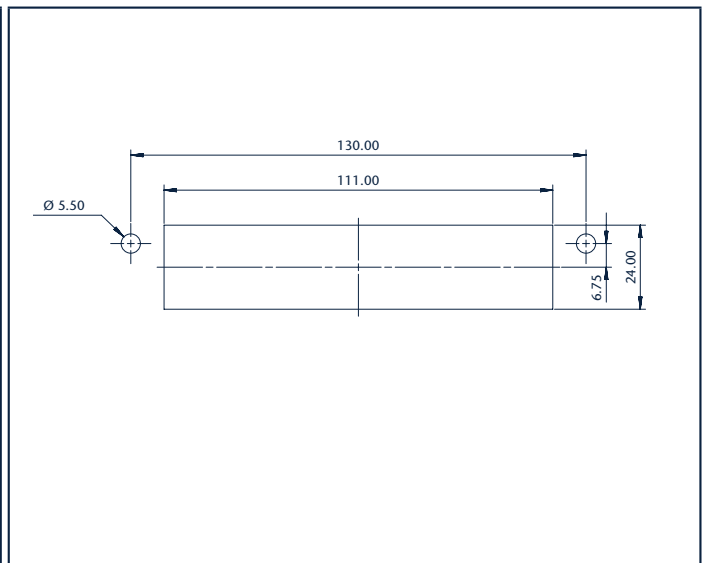

Torque for the frame's mounting screw: 3 Nm

Mounting cut-out





Screw for usage: ISO 4762 / DIN 912

Seals for KDS-FB

Seals	KDS-DE-FB1/A	KDS-DE-FB1/B	KDS-DE-FB1/C	KDS-DE-FB1/D	KDS-DE-FB1/E	KDS-DE-FB1/F	KDS-DE-FB2/A
							
Type / colour	KDS-DE-FB1/A GR	KDS-DE-FB1/B GR	KDS-DE-FB1/C GR	KDS-DE-FB1/D GR	KDS-DE-FB1/E GR	KDS-DE-FB1/F GR	KDS-DE-FB2/A GR
Cat. no.	28713.6	28714.6	28715.6	28716.6	28717.6	28718.6	28719.6
Qty.	5	5	5	5	5	5	5
Sealing area		Width: 19 ... 23 mm Thickness: 5.5 ... 6 mm	Width: 28 ... 33 mm Thickness: 5.5 ... 6 mm	Width: 24 ... 30 mm Thickness: 8.5 ... 9 mm	Width: 19 ... 24 mm Thickness: 6.5 ... 7 mm	Width: 28 ... 33 mm Thickness: 9 ... 9.5 mm	

Seals	KDS-DE-FB2/B	KDS-DE-FB2/C	KDS-DE-FB2/D	KDS-DE-FB2/E	KDS-DE-FB2/F	KDS-DE-FB3/A	KDS-DE-FB3/B
							
Type / colour	KDS-DE-FB2/B GR	KDS-DE-FB2/C GR	KDS-DE-FB2/D GR	KDS-DE-FB2/E GR	KDS-DE-FB2/F GR	KDS-DE-FB3/A GR	KDS-DE-FB3/B GR
Cat. no.	28720.6	28721.6	28722.6	28723.6	28724.6	28725.6	28726.6
Qty.	5	5	5	5	5	5	5
Sealing area	Width: 32.5 ... 38 mm Thickness: 5 ... 5.5 mm	Width: 45 ... 50.5 mm Thickness: 6 ... 6.5 mm	Width: 47 ... 52 mm Thickness: 9.5 ... 10 mm	Width: 38 ... 43 mm Thickness: 12.5 ... 13 mm	Width: 49 ... 54 mm Thickness: 5 ... 6 mm		Width: 72 ... 77 mm Thickness: 5 ... 5.5 mm



Seals	KDS-DE-FB1/A	KDS-DE-FB4/B
		
Type / colour	KDS-DE-FB4/A GR	KDS-DE-FB4/B GR
Cat. no.	28727.6	28728.6
Qty.	5	5
Sealing area		Width: 85 ... 99 mm Thickness: 4.2 ... 5.2 mm



Features

- Material: TPE
- Flammability: UL 94 V-0
- Temperature range: -40 °C to +90 °C (static)
- Halogen-free, silicone-free
- Protection: IP66

Seals for all KDS systems

Seals		grey small			
Type		Cat. no.	Qty.	Max. Ø	
		KDS-DE/B GR	28561.6	10	Blind
		KDS-DE 1.5 GR	28694.6	10	1.5 mm
		KDS-DE 1.5-2 GR	28562.6	10	2 mm
		KDS-DE 2 GR	28696.6	10	2 mm
		KDS-DE 2-3 GR	28563.6	10	3 mm
		KDS-DE 3 GR	28698.6	10	3 mm
		KDS-DE 3-4 GR	28564.6	10	4 mm
		KDS-DE 4-5 GR	28565.6	10	5 mm
		KDS-DE 5-6 GR	28566.6	10	6 mm
		KDS-DE 6-7 GR	28567.6	10	7 mm
		KDS-DE 7-8 GR	28568.6	10	8 mm
		KDS-DE 8-9 GR	28569.6	10	9 mm
		KDS-DE 9-10 GR	28570.6	10	10 mm
		KDS-DE 10-11 GR	28571.6	10	11 mm
		KDS-DE 11-12 GR	28572.6	10	12 mm
		KDS-DE 12-13 GR	28573.6	10	13 mm
		KDS-DE 13-14 GR	28574.6	10	14 mm
		KDS-DE 14-15 GR	28609.6	10	15 mm
		KDS-DE 15-16 GR	28671.6	10	16 mm
Seals with multiple holes		grey			
		KDS-DE 2 x 4-5 GR	28595.6	10	5 mm
		KDS-DE 2 x 5-6 GR	28596.6	10	6 mm
		KDS-DE 2 x 6.5 GR	28607.6	10	6.5 mm
		KDS-DE 2 x 7 GR	28690.6	10	7 mm
		KDS-DE 2 x 8 GR	28692.6	10	8 mm
		KDS-DE 3 x 5-6 GR	28688.6	10	6 mm
		KDS-DE 4 x 2-3 GR	28597.6	10	3 mm
		KDS-DE 4 x 3-4 GR	28598.6	10	4 mm
		KDS-DE 4 x 4.5 GR	28606.6	10	4.5 mm
		KDS-DE 4 x 5 GR	28673.6	10	5 mm
Seals for AS interface cables		grey			
		KDS-DE/1 x ASI GR	28599.6	10	
		KDS-DE/2 x ASI GR	28600.6	10	

	IP66	NEMA TYPE 12	NEMA TYPE 4X
ECOLAB certified	RoHS compliant	Made in Germany	



Features

- Material: TPE
- Flammability: UL 94 V-0
- Temperature range: -40 °C to +90 °C (static)
- Halogen-free, silicone-free
- Protection: IP66

Cat. no.	KDS-SR-FB1/A BK 28700.4	KDS-SR-FB2/A BK 28701.4	KDS-SR-FB2/B BK 28702.4	KDS-SR-FB3/A BK 28703.4	KDS-SR-FB3/B BK 28704.4	KDS-SR-FB3/C BK 28705.4
						
 KDS-DE-FB1/A GR 28713.6	•		•		•	
 KDS-DE-FB1/B GR 28714.6	•		•			•
 KDS-DE-FB1/C GR 28715.6	•		•			•
 KDS-DE-FB1/D GR 28716.6	•		•			•
 KDS-DE-FB1/E GR 28717.6	•		•			•
 KDS-DE-FB1/F GR 28718.6	•		•			•
 KDS-DE-FB2/A GR 28719.6		•			•	
 KDS-DE-FB2/B GR 28720.6		•			•	
 KDS-DE-FB2/C GR 28721.6		•			•	
 KDS-DE-FB2/D GR 28722.4		•			•	
 KDS-DE-FB2/E GR 28723.6		•			•	
 KDS-DE-FB2/F GR 28724.6		•			•	
 KDS-DE-FB3/A GR 28725.6				•		
 KDS-DE-FB3/B GR 28726.6				•		
 KDS-DE-FB4/A GR 28727.6						
 KDS-DE-FB4/B GR 28728.6						

* An overview of all seals with the external dimensions 20 x 20 can be found on page 17.

KDSClick Modular cable entry system

Revolutionary cable entry systems

Fast. Safe. Turning cables inside out!

The KDSClick cable entry system is a cable management solution for switchgear cabinets, housings and machines that features secure seals and strain relief for pre-assembled and non-assembled cables – with or without connectors. KDSClick saves you time and provides you with maximum versatility.

IP66

It's easy.
It's quick.
It's **KDSClick**.



The basic components of the modular system

Frames. Inlays. Seals. The modular design – 3 basic components – provides more versatility, variability and variety.

1. Frame

Made from a single mould, the one-piece frame is quick and easy to assemble. It is made of sturdy, glass-fibre reinforced plastic. The foamed seal guarantees an optimal seal with IP66 protection, even on painted or rough surfaces.



2. Inlays

The click-in inlays enable needs-based dimensioning of the frame opening, corresponding to the seal being used. An audible "click" confirms a correct installation. So you can variably configure cable entries to match various requirements (for cables, lines, tubing, pneumatic and hydraulic lines).



3. Seals

The conical shape of the seal makes it easy to press in. This also reliably seals the gaps and ensures strain relief in accordance with DIN EN 62444. The seals are installed by pressing them from the inside outwards into the openings of the previously installed inlays. Their wave-cut profile makes them easy to install and ensures a perfect fit around the cables. There are currently over 90 different seals that can be used for sealing cables of various diameters and sizes.



Your advantages: More versatility and safety

The seals can be removed by pressing from the outside inwards. Changes, retrofits, servicing or the readjustment of the cable lengths can be made at any time without dismantling the frame. Unwanted manipulations from the outside can be prevented by using an optional inner locking frame.

KDSClick Modular cable entry system

Supported by:



on the basis of a decision
by the German Bundestag

An overview of your advantages

Attaching the frame

The one-piece frame can be easily and quickly attached to the wall.



Quick inside-outwards assembly for easier servicing work

The frame does not need to be disassembled if your requirements change or if you're carrying out service work.

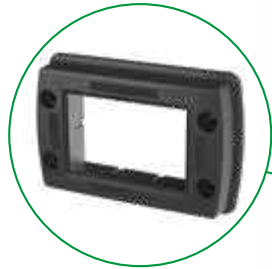

Captive seal

The foamed-in frame gasket eliminates the risk of incorrect assembly (forgotten gasket) and speeds up the assembly process.

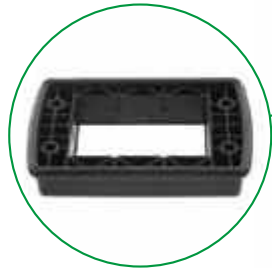

Smart separation of the seals

The wave-cut profile makes them easy to install and ensures a perfect fit around the cables.



No loss of guarantee: assembled cables

No need to disassemble and reconnect connectors, so manufacturer's warranty is not voided.

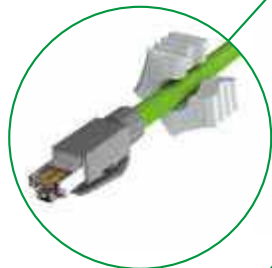

Versatile, high-density assemblies are possible

1-way, 2-way, and 4-way seals provide you with excellent versatility for cable management.

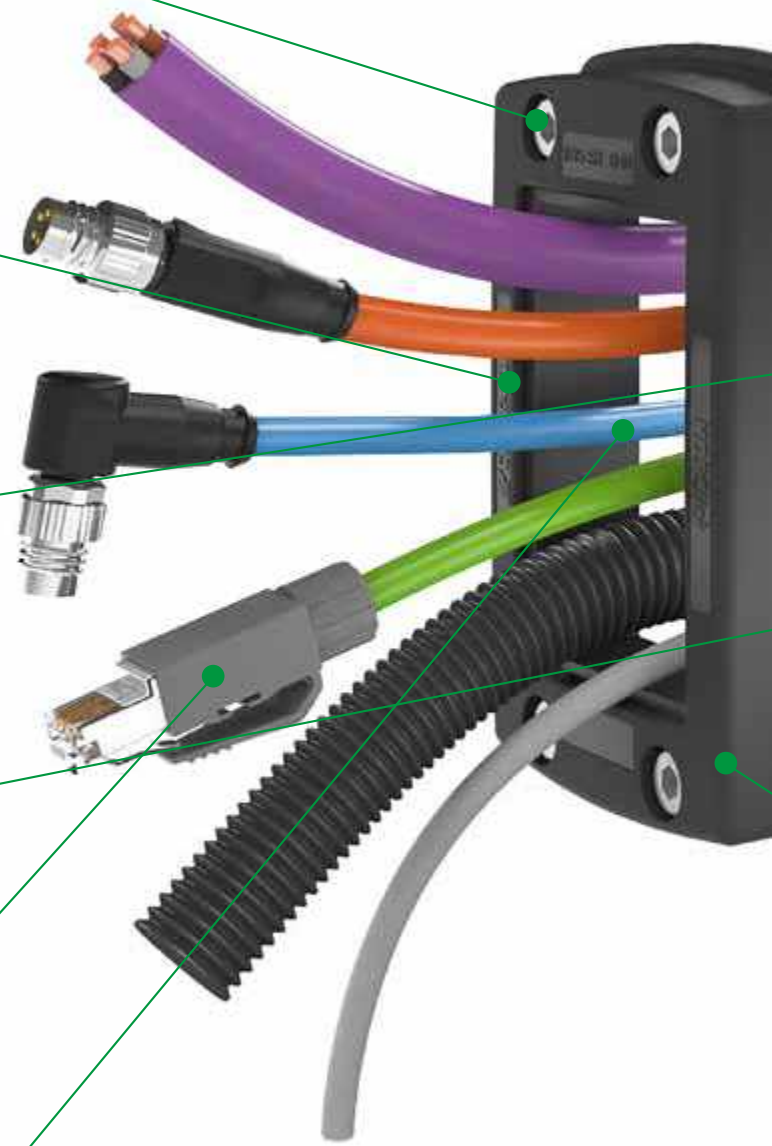

KDS CLICK

by CONTA-CLIP

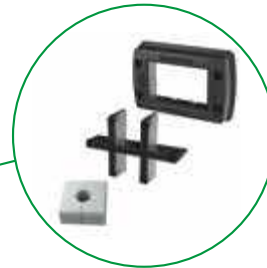
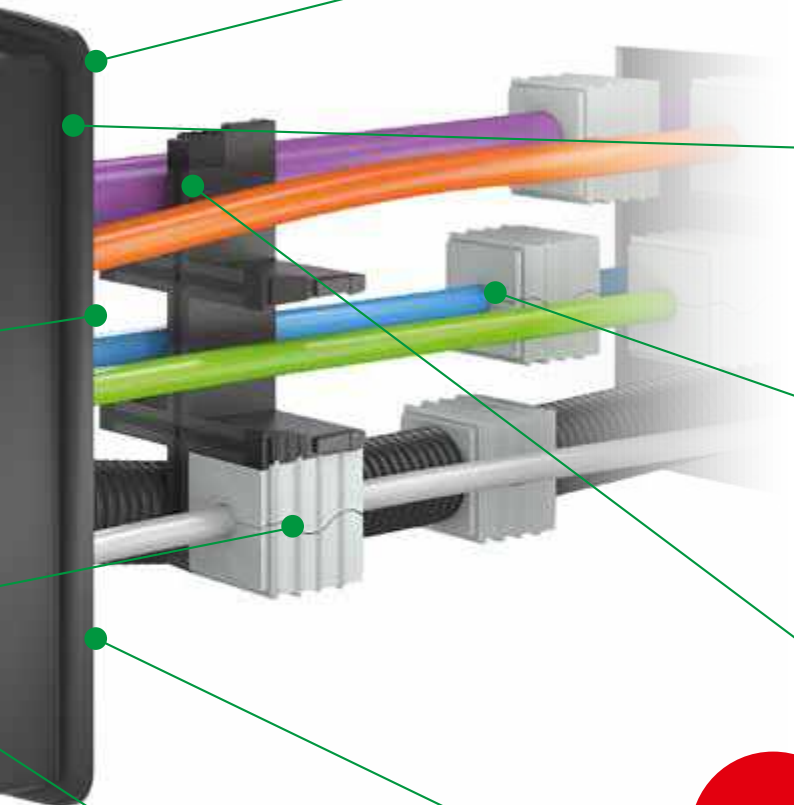

Outstanding versatility with optimized warehousing

The frames, inlays and seals can be combined in many ways – ensuring you many versatile configuration options.



Safe and quick installation with feedback

An audible “click” confirms that the inlay and frame have been properly installed.

Click

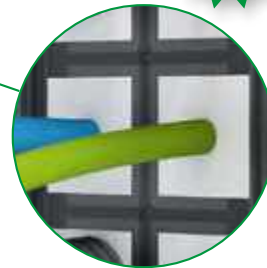

Integrated strain relief

The absolute tightness of the seals ensures a strain relief mechanism for the cables working towards accordance with DIN EN 62444.

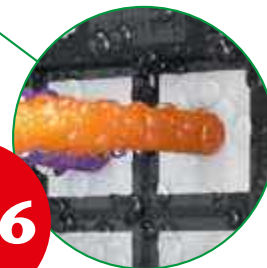

Outstanding IP66 seal

Multi-resistant, tapered seals feature inner and outer sealing gills.

IP66

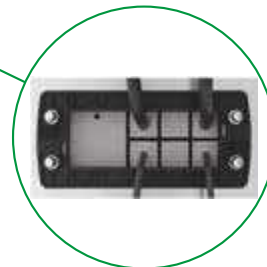

Inner locking frame

The optional locking frame ensures that the seals cannot be pushed out without using tools.

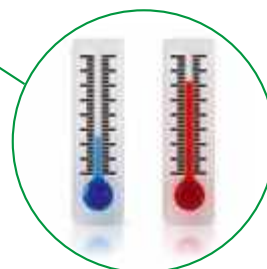

Can be used from –40 °C to +120 °C

Materials contain no halogen or silicone, suitable for many different applications.

	IP66	NEMA TYPE 12	NEMA TYPE 4X
ECOLAB certified	RoHS compliant	Made in Germany	

KDSClick

Modular cable entry system

Frames and inlays	KDS-SR 1-4	KDS-SR 6/10	KDS-SR 8/16	KDS-SR 10/24
				
Diagram	Page 32	Page 32	Page 32	Page 32
Type	KDS-SR 1-4 BK	KDS-SR 6/10 BK	KDS-SR 8/16 BK	KDS-SR 10/24 BK
Cat. no. Qty.	28506.4 1	28500.4 1	28502.4 1	28504.4 1
Description	Screw frame	Screw frame	Screw frame	Screw frame
Type / Set	KDS-Set 1-4 BK	KDS-Set 6/10 BK	KDS-Set 8/16 BK	KDS-Set 10/24 BK
Cat. no. Qty.	28602.4 1	28603.4 1	28604.4 1	28605.4 1
Description	Set consists of: 1 x KDS-SR 1-4 BK, 1 x KDS-Inlay 4 BK	Set consists of: 1 x KDS-SR 6/10 BK, 1 x KDS-Inlay 2 BK, 1 x KDS-Inlay 6 BK	Set consists of: 1 x KDS-SR 8/16 BK, 1 x KDS-Inlay 1 BK, 2 x KDS-Inlay 4 BK	Set consists of: 1 x KDS-Inlay 2 BK, 1 x KDS-Inlay 4 BK, 1 x KDS-Inlay 6 BK
Accessories				
Inlay	KDS-Inlay 4 BK	KDS-Inlay 2 BK	KDS-Inlay 1 BK	KDS-Inlay 2 BK
Cat. no. Qty.	28518.4 5	28517.4 5	28516.4 5	28517.4 5
Description	for 4-way splits	T-shape	For separating vertically	T-shape for large small
Inlay		KDS-Inlay 6 BK	KDS-Inlay 4 BK	KDS-Inlay 4 BK
Cat. no. Qty.		28519.4 5	28518.4 5	28518.4 5
Description		for 6-way splits	for 4-way splits	for 4-way splits
Inlay				KDS-Inlay 6 BK
Cat. no. Qty.				28519.4 5
Description				for 6-way splits
Inner locking frame (optional)	KDS-IVR 1-4 BK	KDS-IVR 6/10 BK	KDS-IVR 8/16 BK	KDS-IVR 10/24 BK
Cat. no. Qty.	28507.4 10	28501.4 10	28503.4 10	28505.4 10
Sheet-metal punch	BL KDS-SR 1-4	BL KDS-SR 6/10	BL KDS-SR 8/16	BL KDS-SR 10/24
Cat. no. Qty.	Page 54	Page 54	Page 54	Page 55
Description	For sheet steel up to 2 mm; also for marking drilling hole points	For sheet steel up to 2 mm; also for marking drilling hole points	For sheet steel up to 2 mm; also for marking drilling hole points	For sheet steel up to 2 mm; also for marking drilling hole points
Actuating tool	KDS BW 1	KDS BW 1	KDS BW 1	KDS BW 1
Cat. no. Qty.	Page 40	Page 40	Page 40	Page 40
Seals				
small	KDS-DE	KDS-DE	KDS-DE	KDS-DE
Cat. no. Qty.	Page 42/43 10	Page 42/43 10	Page 42/43 10	Page 42/43 10
large	KDS-DEG	KDS-DEG	KDS-DEG	KDS-DEG
Cat. no. Qty.	Page 42/43 10	Page 42/43 10	Page 42/43 10	Page 42/43 10



IP66

NEMA
TYPE
12NEMA
TYPE
4XECOLAB
certifiedRoHS
compliantMade in
Germany

Features

- Material: polyamide PA 6.6, glass-fibre reinforced | TPE
- Colour: black
- Flammability: UL 94 V-0
- Temperature range: -40 °C to +120 °C
- Halogen-free, silicone-free
- Protection: IP66

KDSClick Combination options

Combination options with KDS-SR 1-4



KDS-Inlay 4 BK
28518.4



Combination options with KDS-SR 6/10



KDS-Inlay 6 BK
28519.4



KDS-Inlay 2 BK
28517.4

Combination options with KDS-SR 8/16



KDS-Inlay 4 BK
28518.4



KDS-Inlay 1 BK
28516.4



KDS-Inlay 4 BK
28518.4



KDS-Inlay 4 BK
28518.4



KDS-Inlay 1 BK
28516.4

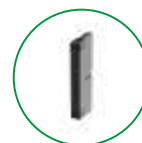

KDS-Inlay 1 BK
28516.4

Combination options with KDS-SR 10/24



KDS-Inlay 4 BK
28518.4



KDS-Inlay 6 BK
28519.4



KDS-Inlay 6 BK
28519.4



KDS-Inlay 2 BK
28517.4

KDS-FP Flange plates

New versatility for managing cables

The new KDS-FP flange plate provides manufacturers of machines with a very cost-effective, convenient feed-through solution. It can be used to adapt housings and switchgear cabinets to fit your updated requirements at any time, and can also considerably simplify your warehousing. You no longer have to stock switchgear cabinets or distributors with different configurations of assembled cable and cable outlets. Instead, you can uniformly prepare your products with the flange plate and then adapt them at any time to your specific cabling or tubing requirements.

In the future, CONTA-CLIP will also offer the flange plates of the KDS-FP series in other shapes and sizes. Your advantage is that you save money by requiring fewer variants.

IP66



Your advantages

- Lower costs with increased variability due to standardized opening dimensions
- No loss of guarantee when using assembled cables
- Versatile, high-density assemblies are possible
- Outstanding IP66 seal
- Integrated strain relief
- Outstanding versatility with optimized warehousing
- Can be used from $-40\text{ }^{\circ}\text{C}$ to $+120\text{ }^{\circ}\text{C}$

The basic components of the modular system

Flange plate. Inlays. Seals. The modular design – 3 basic components – provides more versatility, variability and variety.

1. Flange plate

The flange plate is available in the versions KDS-FP 2x10/24 (up to 20 feed-through openings) or the KDS-FP 3x10/24 (for up to 20 or 30 openings). Uniform housing break-outs of 131 mm x 110 mm or 131 mm x 161 mm are used for installation. By screwing the flange plate on the outside of the cabinet, the break-out is completely sealed according to IP66. On the continuous closed plates, there are two or three cover segments with pre-determined breaking points; these can be pushed out (without tools) which then opens up a 40 mm x 110 mm feed-through opening. The click-in KDSClick frame inlays can be used to subdivide this opening in up to ten appropriately sized frame openings.



2. Inlays

The click-in inlays enable needs-based dimensioning of the frame opening, corresponding to the seal being used. An audible "click" confirms a correct installation. So you can variably configure cable entries to match various requirements (for cables, lines, tubing, pneumatic and hydraulic lines).



3. Seals

The conical shape of the seal makes it easy to press in. This also reliably seals the gaps and ensures strain relief in accordance with DIN EN 62444. The seals are installed by pressing them from the inside outwards into the openings of the previously installed inlays. Their wave-cut profile makes them easy to install and ensures a perfect fit around the cables. There are currently over 90 different seals that can be used for sealing cables of various diameters and sizes.



KDS-FP Flange plate

An overview of your advantages

Flange plate is easy to install

The one-piece flange plate can be easily and quickly attached to the wall.

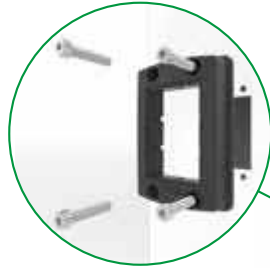

Captive seal

The foamed-in frame gasket eliminates the risk of incorrect assembly (forgotten gasket) and speeds up the assembly process.



Variability

Can be extended to max. 30 openings, without the use of tools or further machining.



No loss of guarantee: assembled cables

No need to disassemble and reconnect connectors, so manufacturer's warranty is not voided.

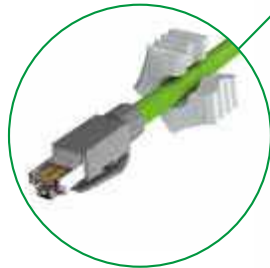

Versatile, high-density assemblies are possible

1-way, 2-way, and 4-way seals provide you with excellent versatility for cable management.



Accessories

Locking mechanism can be installed without tools; this provides additional strain relief in direction of cabinet interior.

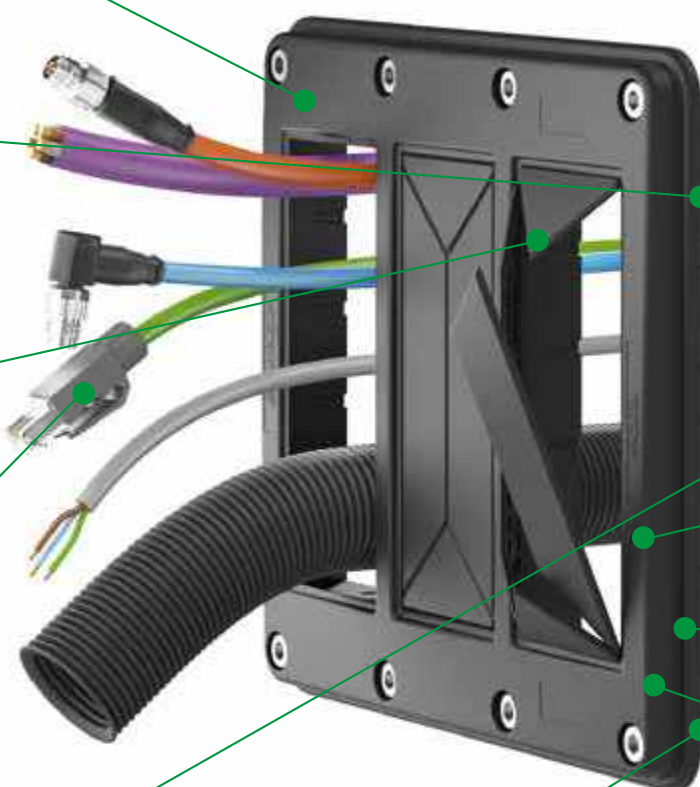

KDS CLICK

by CONTA-CLIP

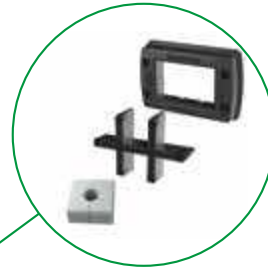

Outstanding versatility with optimized warehousing

The flange plates, inlays and seals can be combined in many ways – ensuring you many versatile configuration options.



Safe and quick installation with feedback

An audible "click" confirms that the inlay and frame have been properly installed.

Click

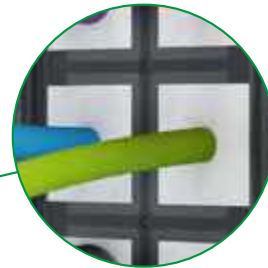

Integrated strain relief

The absolute tightness of the seals ensures a strain relief mechanism for the cables that complies with DIN EN 62444.



Outstanding IP66 seal

Multi-resistant, tapered seals feature inner and outer sealing gills.

IP66

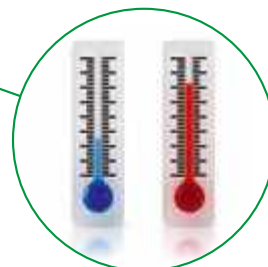

Can be used from –40 °C to +120 °C

Materials contain no halogen or silicone; suitable for many different applications.

KDS-FP Flange plate

Flange plates and accessories		KDS-FP 2x10/24	
			
Diagram		Page 33	
Type		KDS-FP 2x10/24 BK	
<i>Cat. no.</i>	Qty.	28660.4	1
Description		Flange plate	
Accessories			
Inlay		KDS-Inlay 1 BK	
<i>Cat. no.</i>	Qty.	28516.4	5
Description		For separating vertically	
Inlay		KDS-Inlay 2 BK	
<i>Cat. no.</i>	Qty.	28517.4	5
Description		T-shape for large small	
Inlay		KDS-Inlay 4 BK	
<i>Cat. no.</i>	Qty.	28518.4	5
Description		for 4-way splits	
Inlay		KDS-Inlay 6 BK	
<i>Cat. no.</i>	Qty.	28519.4	5
Description		for 6-way splits	
Inner lock		KDS-FP-IVR OG	
<i>Cat. no.</i>	Qty.	28664.3	20
Actuating tool		KDS BW 1	
<i>Cat. no.</i>	Qty.	Page 40	

Flange plates and accessories		KDS-FP 3x10/24 BK	
			
Diagram		Page 33	
Type		KDS-FP 3x10/24 BK	
<i>Cat. no.</i>	Qty.	28661.4	1
Description		Flange plate	
Accessories			
Inlay		KDS-Inlay 1 BK	
<i>Cat. no.</i>	Qty.	28516.4	5
Description		For separating vertically	
Inlay		KDS-Inlay 2 BK	
<i>Cat. no.</i>	Qty.	28517.4	5
Description		T-shape for large small	
Inlay		KDS-Inlay 4 BK	
<i>Cat. no.</i>	Qty.	28518.4	5
Description		for 4-way splits	
Inlay		KDS-Inlay 6 BK	
<i>Cat. no.</i>	Qty.	28519.4	5
Description		for 6-way splits	
Inner lock		KDS-FP-IVR OG	
<i>Cat. no.</i>	Qty.	28664.3	20
Actuating tool		KDS BW 1	
<i>Cat. no.</i>	Qty.	Page 40	

KDS-FP

Combination options

Combination option 1



KDS-Inlay 4 BK
28518.4

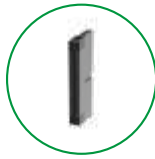

KDS-Inlay 1 BK
28516.4



KDS-Inlay 6 BK
28519.4

Combination option 2



KDS-Inlay 1 BK
28516.4



KDS-Inlay 6 BK
28519.4

Combination option 3

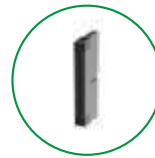

KDS-Inlay 1 BK
28516.4



KDS-Inlay 2 BK
28517.4

Each of the two or three 10-frame openings can be configured with the appropriate inlays to match a wide variety of customer requirements.



Features

- Material: polyamide PA 6.6, glass-fibre reinforced | TPE
- Colour: black
- Flammability: UL 94 V-0
- Temperature range: -40 °C to +120 °C
- Halogen-free, silicone-free
- Protection: IP66

KDSClick: dimensional drawings / mounting cut-outs

Modular cable entry system

KDS-SR 1-4

Dimension diagram

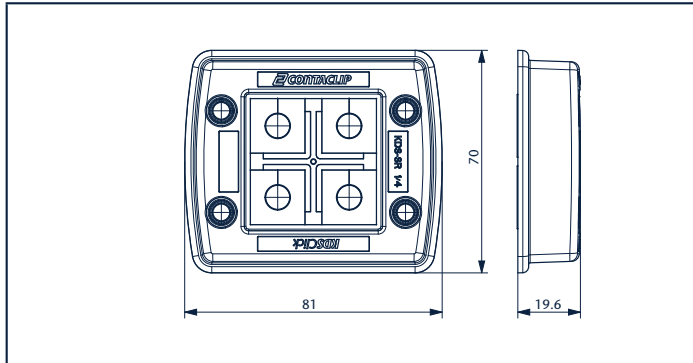

Mounting cut-out

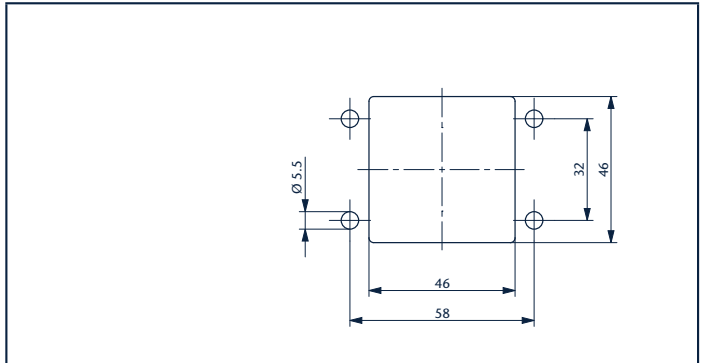

Torque for the frame's mounting screw: 3 Nm

Screw for usage: ISO 4762 / DIN 912

KDS-SR 6/10

Dimension diagram

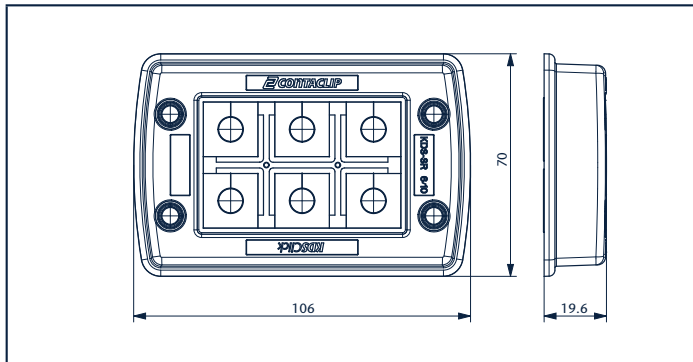

Mounting cut-out

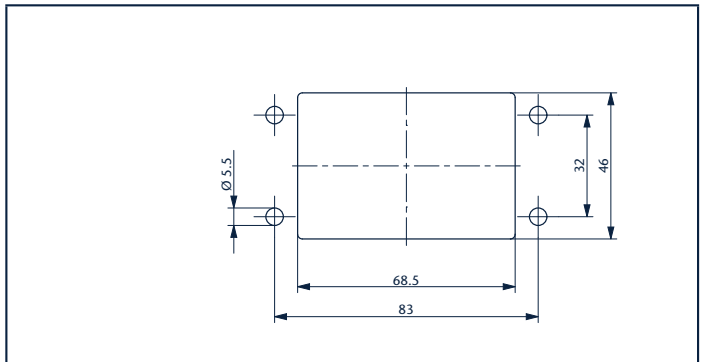

Torque for the frame's mounting screw: 3 Nm

Screw for usage: ISO 4762 / DIN 912

KDS-SR 8/16

Dimension diagram

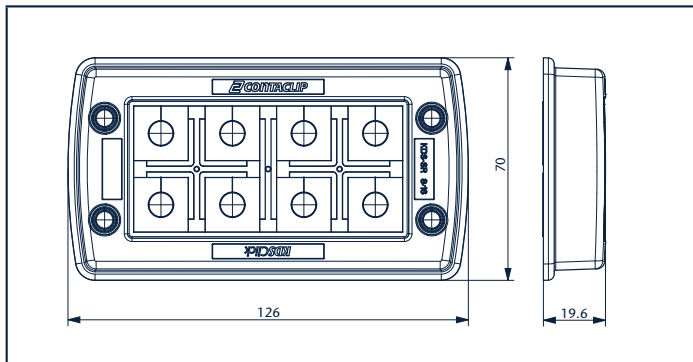

Mounting cut-out

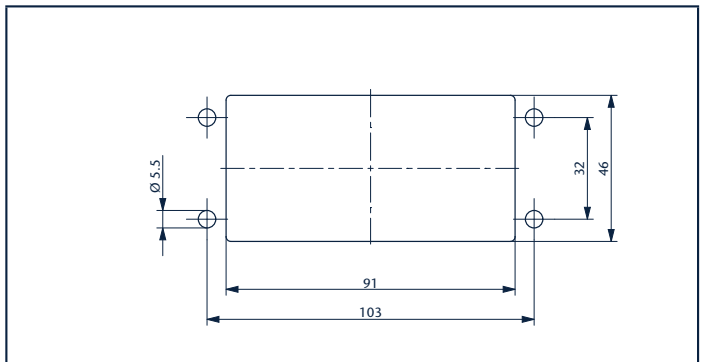

Torque for the frame's mounting screw: 3 Nm

Screw for usage: ISO 4762 / DIN 912

KDS-SR 10/24

Dimension diagram

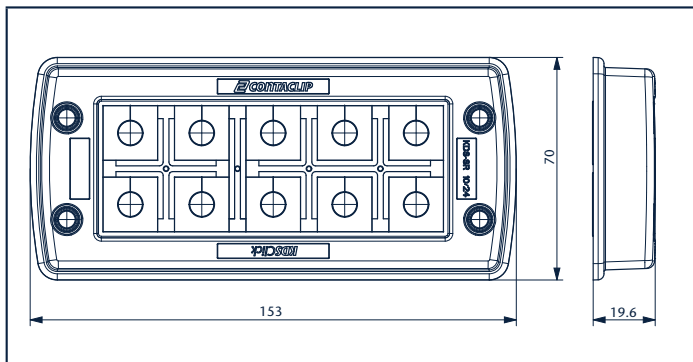

Mounting cut-out

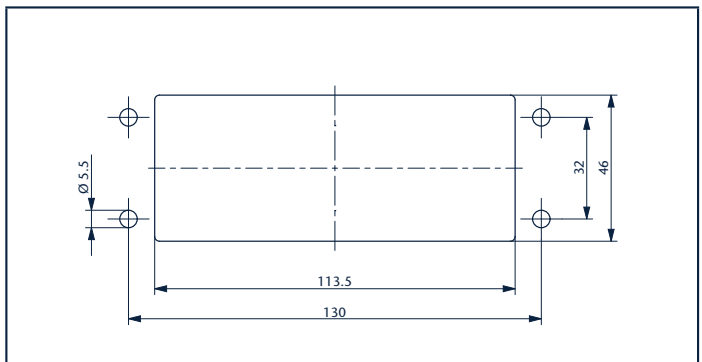

Torque for the frame's mounting screw: 3 Nm

Screw for usage: ISO 4762 / DIN 912

KDS-FP: dimensional drawings / mounting cut-outs

Flange plate

KDS-FP 2x10/24

Dimension diagram

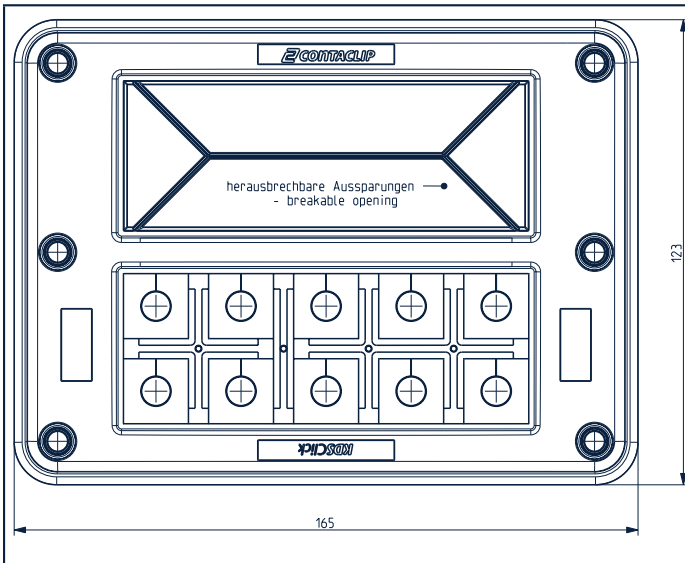

Mounting cut-out

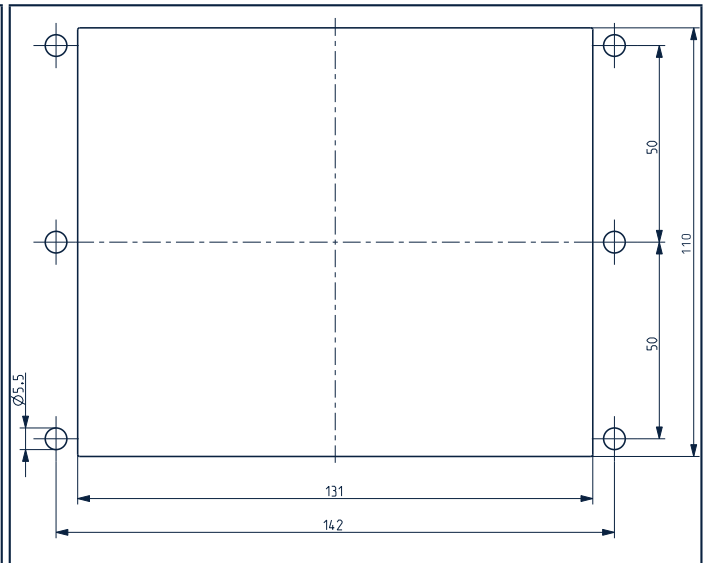

Torque for the frame's mounting screw: 3 Nm

Screw for usage: ISO 4762 / DIN 912

KDS-FP 3x10/24

Dimension diagram

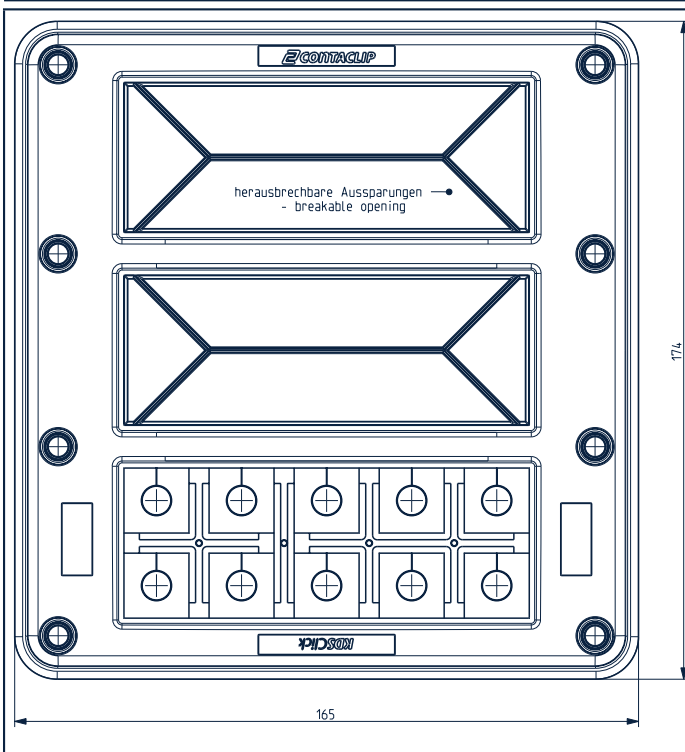

Mounting cut-out

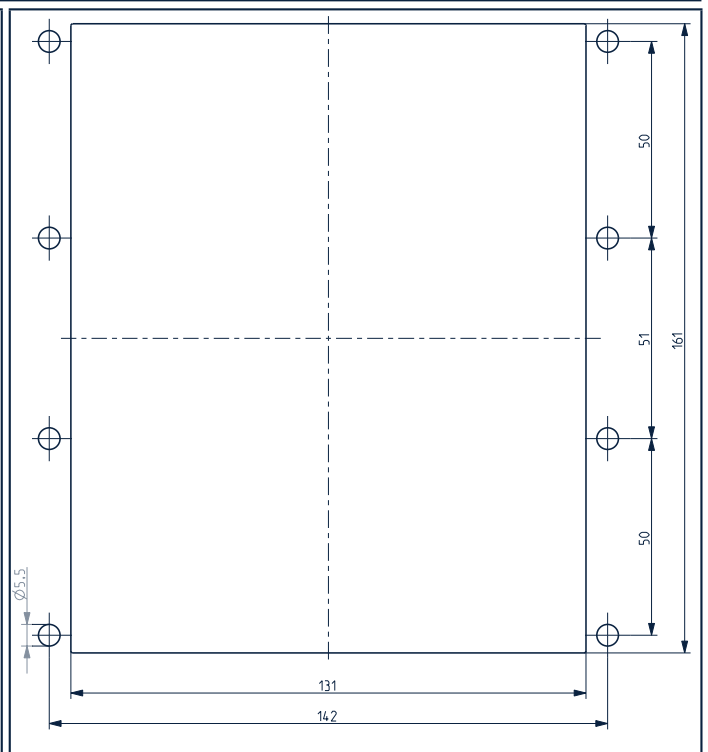

Torque for the frame's mounting screw: 3 Nm

Screw for usage: ISO 4762 / DIN 912

KDS-KV

Separable cable glands

All-round "cornered" solutions for your requirements!

For metric break-outs from M20 to M63, CONTA-CLIP provides separable cable glands for cables with or without attached plugs. In case of maintenance or retrofitting with assembled cable harnesses, cables with diameters from 2 to 35 mm can be quickly and safely inserted into the switchgear cabinets or housings and sealed according to IP66. This separable system ensures quick and simple installation. The slitted seal has a wave-cut profile that ensures a reliable seal and a totally secure attachment.

The seal is first placed around the cable and then inserted in one of the two halves of the cable gland. After inserting the seals, the two halves of the cable gland are simply snapped together. A locknut (which can also be separated) on the inside of the cabinet ensures a safe and secure attachment.



Your advantages

- Assembled cables can be guided through
- Guarantee retained for assembled cables
- Retrofitting and servicing can be done quickly and easily
- High-density assemblies
- Can be installed on standard metric break-outs
- Includes a separable hexagon nut

The basic components of the modular system

Split cable glands

Consisting of two half-shells, the cable gland is quick and easy to install. It is made of dimensionally stable, glass-fibre reinforced plastic. The integrated seal guarantees an optimal seal with IP66 protection, even on painted or rough surfaces.



Separable locknuts

The individual parts of the locknut can be snapped together quickly and easily via the dovetail guide and then mounted with the gland.



Seals

The conical shape of the seal makes it easy to press in. This also reliably seals the gaps and ensures strain relief in accordance with DIN EN 62444. The seals are installed by pressing them from the inside outwards into the openings of the previously installed inlays. Their wave-cut profile makes them easy to install and ensures a perfect fit around the cables. There are currently over 90 different seals that can be used for sealing cables of various diameters and sizes.



KDS-KV Separable cable glands

An overview of your advantages

Mounting

No tools are required to mount the cable gland.



Variability

Up to 4 cables can be fed through using just one cable gland.

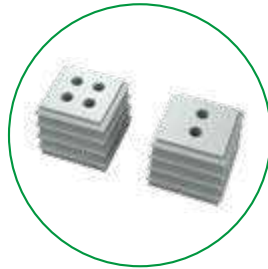

No loss of guarantee with assembled cables

No need to disassemble and reconnect connectors, so the manufacturer's warranty is not voided.

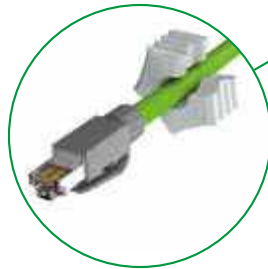

Versatile, high-density assemblies are possible

1-way, 2-way, and 4-way seals provide you with excellent versatility for cable management.

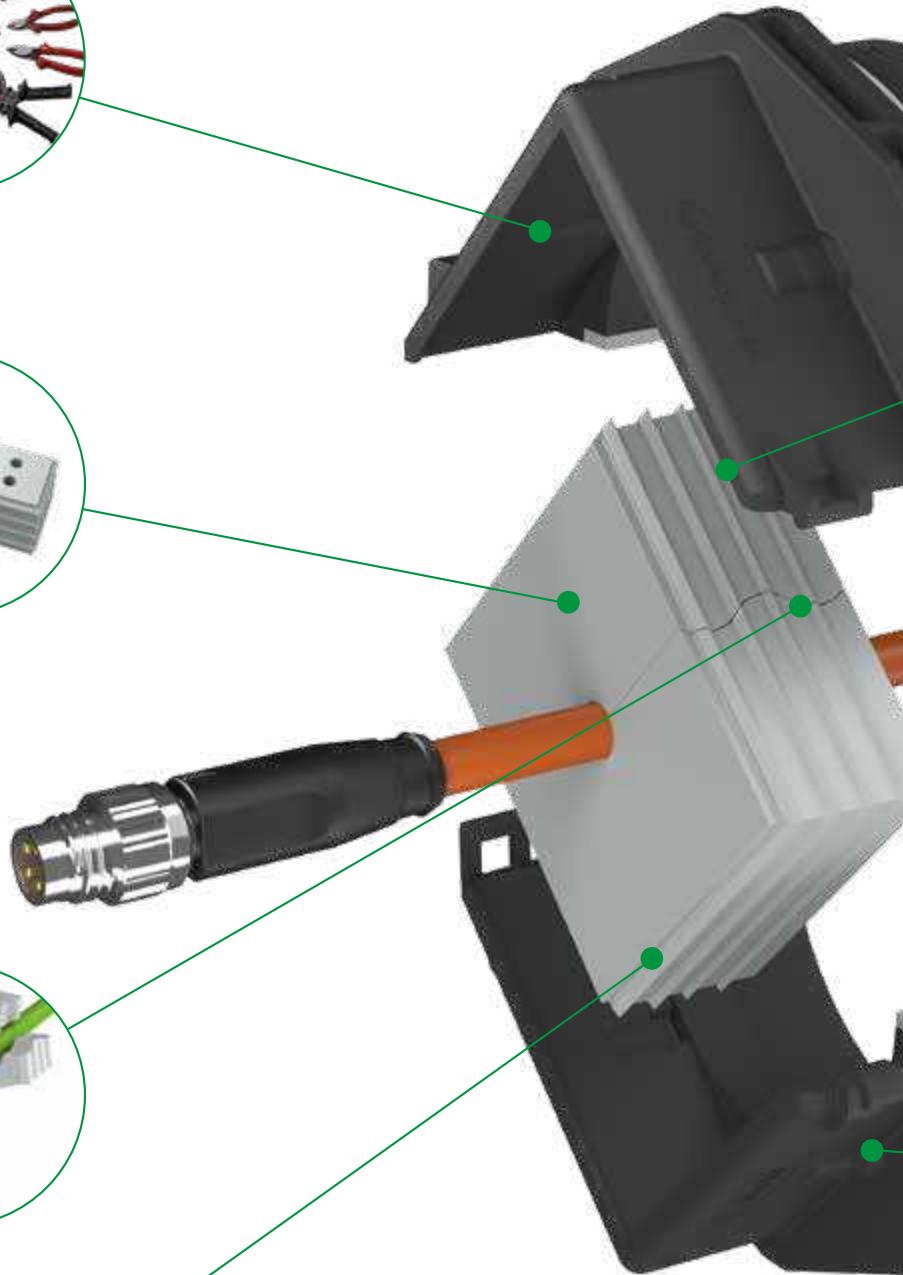
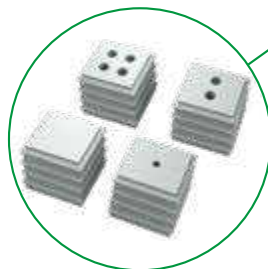

**IP66****Outstanding IP66 seal**

Multi-resistant, tapered seals feature inner and outer sealing gills.

**Integrated strain relief**

The absolute tightness of the seals ensures a strain relief mechanism for the cables that complies with DIN EN 62444.

**Facility availability**

Since the cable gland and the locknut are separable, servicing can be carried out during operations.

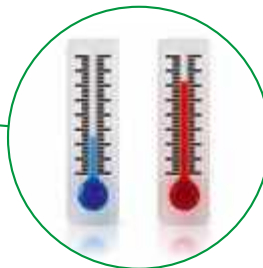







**Can be used from
-40 °C to +120 °C**

Materials contain no halogen or silicone; suitable for many different applications.

KDS-KV

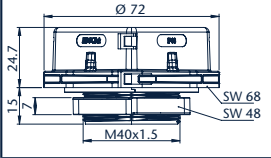
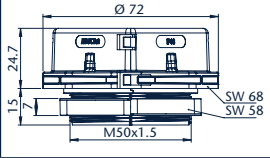
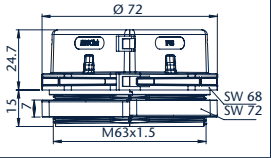
Separable cable glands

Separable cable glands	KDS-KV M20	KDS-KV M25	KDS-KV M32
			
Diagram			
Type	KDS-KV M20 BK	KDS-KV M25 BK	KDS-KV M32 BK
<i>Cat. no.</i>	28610.4	28611.4	28612.4
<i>Qty.</i>	10	10	10
Description	Separable cable gland, including separable locknut	Separable cable gland, including separable locknut	Separable cable gland, including separable locknut
Cable diameter, mm			
KDS-DE	1-13	1-14	1-14
Accessories			
Locknut	KDS-GM 20 BK	KDS-GM 25 BK	KDS-GM 32 BK
<i>Cat. no.</i>	28616.4	28617.4	28618.4
<i>Qty.</i>	10	10	10
Description	Separable locknut	Separable locknut	Separable locknut
Seals			
small	KDS-DE	KDS-DE	KDS-DE
<i>Cat. no.</i>	Page 42/43	Page 42/43	Page 42/43
Tightening torque of lock nut, in Nm	4	4	4
Combinations			

Separable cable glands		KDS-KV M40	KDS-KV M50	KDS-KV M63
				
Diagram				
Type		KDS-KV M40 BK	KDS-KV M50 BK	KDS-KV M63 BK
Cat. no.	Qty.	28613.4	28614.4	28615.4
Description		Separable cable gland, including separable locknut	Separable cable gland, including separable locknut	Separable cable gland, including separable locknut
Cable diameter, mm		14-33	14-33	14-33
Accessories				
Locknut		KDS-GM 40 BK	KDS-GM 50 BK	KDS-GM 63 BK
Cat. no.	Qty.	28619.4	28620.4	28621.4
Description		Separable locknut	Separable locknut	Separable locknut
Seals				
small		KDS-DEG	KDS-DEG	KDS-DEG
Cat. no.	Qty.	Page 42/43	Page 42/43	Page 42/43
Tightening torque of lock nut, in Nm		7	7	7
Combinations				



Features

- Material: polyamide PA 6.6, glass-fibre reinforced | TPE
- Colour: black
- Flammability: UL 94 V-0
- Temperature range: -40 °C to +120 °C
- Halogen-free, silicone-free
- Protection: IP66

Actuating tool KDS BW 1

Using the KDS BW1 actuating tool, the seals can be conveniently mounted in and dismantled from the frame. The ergonomic grip and the special shape enable simple and precise installations, especially for cabling applications in confined spaces.



Actuating tool



KDS BW 1



Type	KDS BW 1
Cat. no.	28622.0
Description	Actuating tool
Material	PA 6.6
Colour	varies

Shield-connection rails KDS-EMV-SAB

The KDS-EMV-SAB shield-connection rails, when used together with our different shield-connection clips, enable cables to be shielded in a quick, practical and uncomplicated process. The cables can be routed through the CONTA-CLIP cable entry systems into housing or switchgear cabinets.

The KDS-EMV-SAB shield-connection rails are fastened on the inside of the switchgear cabinet using screws, which are required for mounting the KDS/KES system. The appropriate shield clip (depending on the cable diameter) can then be snapped onto the shield-connection rail. The shield-connection clips/brackets are optionally available with a built-in strain relief function.



Shield-connection rails		KDS-EMV-SAB 1-4	KDS-EMV-SAB 6/10
Diagram			
Type		KDS-EMV-SAB 1-4	KDS-EMV-SAB 6/10
Cat. no.	Qty.	28623.0	28624.0
Suitable for		KDS-SR 1-4 BK	KDS-SR 6/10 BK
		10	10
Shield-connection rails		KDS-EMV-SAB 8/16	KDS-EMV-SAB 10/24
Diagram			
Type		KDS-EMV-SAB 8/16	KDS-EMV-SAB 10/24
Cat. no.	Qty.	28625.0	28626.0
Suitable for		KDS-SR 8/16 BK	KDS-SR 10/24 BK KES.../24 KES-GB.../24
		10	10

Sealing elements for all KDS systems

Seals	grey small		
	Type	Cat. no.	Qty. Max. Ø
	KDS-DE/B GR	28561.6	10 Blind
	KDS-DE 1.5-2 GR	28562.6	10 2 mm
	KDS-DE 2-3 GR	28563.6	10 3 mm
	KDS-DE 3-4 GR	28564.6	10 4 mm
	KDS-DE 4-5 GR	28565.6	10 5 mm
	KDS-DE 5-6 GR	28566.6	10 6 mm
	KDS-DE 6-7 GR	28567.6	10 7 mm
	KDS-DE 7-8 GR	28568.6	10 8 mm
	KDS-DE 8-9 GR	28569.6	10 9 mm
	KDS-DE 9-10 GR	28570.6	10 10 mm
	KDS-DE 10-11 GR	28571.6	10 11 mm
	KDS-DE 11-12 GR	28572.6	10 12 mm
	KDS-DE 12-13 GR	28573.6	10 13 mm
	KDS-DE 13-14 GR	28574.6	10 14 mm
	KDS-DE 14-15 GR	28609.6	10 15 mm
	KDS-DE 15-16 GR	28671.6	10 16 mm
Seals	grey large		
	KDS-DEG/B GR	28575.6	10 Blind
	KDS-DEG 14-15 GR	28576.6	10 15 mm
	KDS-DEG 15-16 GR	28577.6	10 16 mm
	KDS-DEG 16-17 GR	28578.6	10 17 mm
	KDS-DEG 17-18 GR	28579.6	10 18 mm
	KDS-DEG 18-19 GR	28580.6	10 19 mm
	KDS-DEG 19-20 GR	28581.6	10 20 mm
	KDS-DEG 20-21 GR	28582.6	10 21 mm
	KDS-DEG 21-22 GR	28583.6	10 22 mm
	KDS-DEG 22-23 GR	28584.6	10 23 mm
	KDS-DEG 23-24 GR	28585.6	10 24 mm
	KDS-DEG 24-25 GR	28586.6	10 25 mm
	KDS-DEG 25-26 GR	28587.6	10 26 mm
	KDS-DEG 26-27 GR	28588.6	10 27 mm
	KDS-DEG 27-28 GR	28589.6	10 28 mm
	KDS-DEG 28-29 GR	28590.6	10 29 mm
	KDS-DEG 29-30 GR	28591.6	10 30 mm
KDS-DEG 30-31 GR	28592.6	10 31 mm	
KDS-DEG 31-32 GR	28593.6	10 32 mm	
KDS-DEG 32-33 GR	28594.6	10 33 mm	
Seals with multiple holes	grey		
	KDS-DE 2x4-5 GR	28595.6	10 5 mm
	KDS-DE 2x5-6 GR	28596.6	10 6 mm
	KDS-DE 2x6,5 GR	28607.6	10 6.5 mm
	KDS-DE 2x7 GR	28690.6	10 7 mm
	KDS-DE 2x8 GR	28692.6	10 8 mm
	KDS-DE 3x5-6 GR	28688.6	10 6 mm
	KDS-DE 4x2-3 GR	28597.6	10 3 mm
	KDS-DE 4x3-4 GR	28598.6	10 4 mm
	KDS-DE 4x5 GR	28673.6	10 5 mm
	KDS-DE 4x4,5 GR	28606.6	10 4.5 mm
	KDS-DE 4x6 GR	28762.6	10 6 mm
Seals for AS interface cables	grey		
	KDS-DE/1 x ASI GR	28599.6	10
	KDS-DE/2 x ASI GR	28600.6	10



IP66

NEMA
TYPE
12NEMA
TYPE
4XECOLAB
certifiedRoHS
compliantMade in
Germany

Features

- Material: TPE
- Flammability: UL 94 V-0
- Temperature range: -40 °C to +90 °C (static)
- Halogen-free, silicone-free
- Protection: IP66

Seals	black small		
	Type	Cat. no.	Qty. Max. Ø
	KDS-DE/B BK	28520.4	10 Blind
	KDS-DE 1.5-2 BK	28521.4	10 2 mm
	KDS-DE 2-3 BK	28522.4	10 3 mm
	KDS-DE 3-4 BK	28523.4	10 4 mm
	KDS-DE 4-5 BK	28524.4	10 5 mm
	KDS-DE 5-6 BK	28525.4	10 6 mm
	KDS-DE 6-7 BK	28526.4	10 7 mm
	KDS-DE 7-8 BK	28527.4	10 8 mm
	KDS-DE 8-9 BK	28528.4	10 9 mm
	KDS-DE 9-10 BK	28529.4	10 10 mm
	KDS-DE 10-11 BK	28530.4	10 11 mm
	KDS-DE 11-12 BK	28531.4	10 12 mm
	KDS-DE 12-13 BK	28532.4	10 13 mm
	KDS-DE 13-14 BK	28533.4	10 14 mm
	KDS-DE 14-15 BK	28608.4	10 15 mm
KDS-DE 15-16 BK	28670.4	10 16 mm	
Seals	black large		
	KDS-DEG/B BK	28534.4	10 Blind
	KDS-DEG 14-15 BK	28535.4	10 15 mm
	KDS-DEG 15-16 BK	28536.4	10 16 mm
	KDS-DEG 16-17 BK	28537.4	10 17 mm
	KDS-DEG 17-18 BK	28538.4	10 18 mm
	KDS-DEG 18-19 BK	28539.4	10 19 mm
	KDS-DEG 19-20 BK	28540.4	10 20 mm
	KDS-DEG 20-21 BK	28541.4	10 21 mm
	KDS-DEG 21-22 BK	28542.4	10 22 mm
	KDS-DEG 22-23 BK	28543.4	10 23 mm
	KDS-DEG 23-24 BK	28544.4	10 24 mm
	KDS-DEG 24-25 BK	28545.4	10 25 mm
	KDS-DEG 25-26 BK	28546.4	10 26 mm
	KDS-DEG 26-27 BK	28547.4	10 27 mm
	KDS-DEG 27-28 BK	28548.4	10 28 mm
	KDS-DEG 28-29 BK	28549.4	10 29 mm
	KDS-DEG 29-30 BK	28550.4	10 30 mm
	KDS-DEG 30-31 BK	28551.4	10 31 mm
KDS-DEG 31-32 BK	28552.4	10 32 mm	
KDS-DEG 32-33 BK	28601.4	10 33 mm	
Seals with multiple holes	black		
	KDS-DE 2x4-5 BK	28555.4	10 5 mm
	KDS-DE 2x5-6 BK	28556.4	10 6 mm
	KDS-DE 2x6,5 BK	28682.4	10 6.5 mm
	KDS-DE 2x7 BK	28689.4	10 7 mm
	KDS-DE 2x8 BK	28691.4	10 8 mm
	KDS-DE 3x5-6 BK	28687.4	10 6 mm
	KDS-DE 4x2-3 BK	28557.4	10 3 mm
	KDS-DE 4x3-4 BK	28558.4	10 4 mm
	KDS-DE 4x5 BK	28672.4	10 5 mm
	KDS-DE 4x4,5 BK	28681.4	10 4.5 mm
	KDS-DE 4x6 BK	28763.4	10 6 mm
Seals for AS interface cables	black		
	KDS-DE/1 x ASI BK	28559.4	10
	KDS-DE/2 x ASI BK	28560.4	10
Cone-shaped seals	black		
	KDS-DE/K 2-11 BK	28553.4	10 11 mm
	KDS-DEG/K 7-24 BK	28554.4	10 24 mm



IP66

NEMA
TYPE
12NEMA
TYPE
4XECOLAB
certifiedRoHS
compliantMade in
Germany

Features

- Material: TPE
- Flammability: UL94 HB
- Temperature range: -40 °C to +120 °C (static)
- Halogen-free, silicone-free
- High chemical resistance
- UV-stabilized
- Protection: IP66

KES cable entries

When feeding in non-assembled cables, lines and pneumatic hoses (without connected plugs), CONTA-CLIP has a wide range of products that offer alternatives to cable glands or single-membrane feed-throughs.

The KES cable entries are very flat; they enable space-saving professional cable entries with a very tight seal.

Due to its high assembly density, the KES system is well suited for applications where the installations are carried out in confined spaces.



Your advantages

- Can be screwed/snapped on
- Very high stability (core: PA 6.6 GF)
- Outstanding strain relief (cone grommet)
- Very simple assembly
(with marked centring point)
- High-density assemblies
- Double sealing / IP66 seal
- Hygienic design: no dirt-prone niches
- Large assortment (48 varieties)
- UL-listed plastic materials
- UL 94 V-0

KES cable entries

Two components

The KES system consists of two components. The inner core, made of polyamide PA 6.6 GF, is crucial for the stability and strain relief; it is over-moulded in the sealing areas with TPE to ensure an IP66 seal.



Many cables in a confined space

Many cables (with various diameters from 3.2 to 20.5 mm) can be inserted in a confined space and double sealed (IP66) thanks to the special construction of the conical grommets. The installation can use a screw-on outer mount optionally using threaded bushes from the inside, or snapping on without screws.

In order to insert the cables, the corresponding membrane (with marked centring point) must be pierced; the cables are then simply guided through.



UL 94 V-0 classification

The KES is designed for use in mounting cut-outs together with 24-pin heavy-duty connectors. All variants are available in grey and black. The materials used comply with the UL 94 V-0 classification.



KES cable entries

An overview of your advantages

High-density assemblies

In contrast to the classic cable gland, the KES allows many cables, hoses and lines to be installed in a space-saving manner, even in cramped installation conditions.



Very precise

The piercing points are clearly marked so that cables and hoses can be centred precisely.

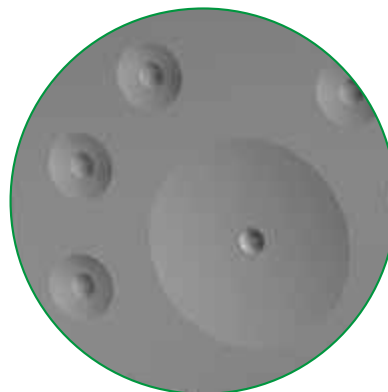

Integrated strain relief

The special shape of the multi-layered membrane cone grommet ensures an optimal strain relief mechanism for the cables, in accordance with DIN EN 62444.

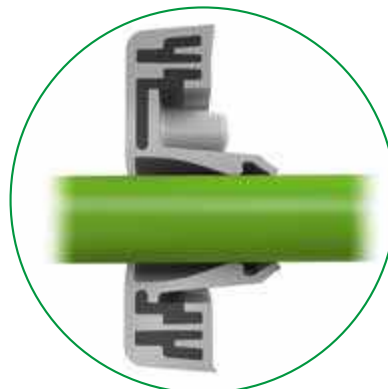

Can be used from

-40 °C to +90 °C

Materials contain no halogen or silicone; suitable for many different applications.

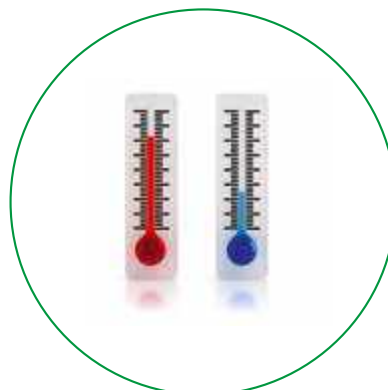

Wide variety of KES variants

You can choose one of three attachment options to fit your requirements.

1. Screw-on mount



The KES (without threaded bush) is screwed from the outside onto the housing wall.

2. Screw-on mount with threaded bushes and latching clips

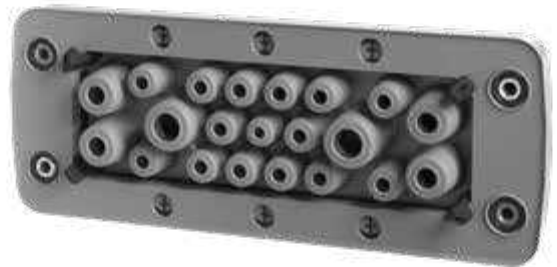



Using the latching clips, the KES-GB latches onto the outside of the housing wall. It is then screwed on from the inside, through the housing wall, using the integrated threaded bushes.

3. Latched (snap-on) mount using latching hooks



The KES-R is latched from outside to the housing wall using the latching clips.

KES cable entries

Cable entries		KES 13/24	KES 14/24	KES 16/24
				
Diagram		Page 50	Page 50	Page 50
Mounting type Screw-on mount				
				
Type / colour		KES 13/24 GR ●	KES 14/24 GR ●	KES 16/24 GR ●
<i>Cat. no.</i>	Qty.	28630.6 10	28631.6 10	28632.6 10
Type / colour		KES 13/24 BK ●	KES 14/24 BK ●	KES 16/24 BK ●
<i>Cat. no.</i>	Qty.	28630.4 10	28631.4 10	28632.4 10
Mounting type Screw-on mount, with pressed-in threaded bush				
				
Type / colour		KES-GB 13/24 GR ●	KES-GB 14/24 GR ●	KES-GB 16/24 GR ●
<i>Cat. no.</i>	Qty.	28640.6 10	28641.6 10	28642.6 10
Type / colour		KES-GB 13/24 BK ●	KES-GB 14/24 BK ●	KES-GB 16/24 BK ●
<i>Cat. no.</i>	Qty.	28640.4 10	28641.4 10	28642.4 10
Mounting type Tool-free latch-on mount				
				
Type / colour		KES-R 13/24 GR ●	KES-R 14/24 GR ●	KES-R 16/24 GR ●
<i>Cat. no.</i>	Qty.	28650.6 10	28651.6 10	28652.6 10
Type / colour		KES-R 13/24 BK ●	KES-R 14/24 BK ●	KES-R 16/24 BK ●
<i>Cat. no.</i>	Qty.	28650.4 10	28651.4 10	28652.4 10
Connection data				
Number of cables x cable diameter		10 x 3.2-6.3 3 x 16-20.5	5 x 3.2-6.3 2 x 4-7.5 3 x 5.5-10.5 1 x 8-12.5 3 x 12-16.2	8 x 3.2-5.5 6 x 5-8.5 2 x 9.5-14.5
Features				
Material of frame / sealing plate		PA 6.6 GF / elastomer	PA 6.6 GF / elastomer	PA 6.6 GF / elastomer
Temperature range		-40 °C to +90 °C	-40 °C to +90 °C	-40 °C to +90 °C
Protection		IP66	IP66	IP66
Flammability class		UL 94 V-0	UL 94 V-0	UL 94 V-0
Sheet-metal punch		Sheet-metal punch	Sheet-metal punch	Sheet-metal punch
<i>Cat. no.</i>		Page 54	Page 54	Page 54



Page 50	Page 51	Page 51	Page 51	Page 51

KES 16-1/24 GR ● 10 28633.6	KES 17/24 GR ● 10 28634.6	KES 20/24 GR ● 10 28635.6	KES 21/24 GR ● 10 28636.6	KES 32/24 GR ● 10 28637.6
KES 16-1/24 BK ● 10 28633.4	KES 17/24 BK ● 10 28634.4	KES 20/24 BK ● 10 28635.4	KES 21/24 BK ● 10 28636.4	KES 32/24 BK ● 10 28637.4

KES-GB 16-1/24 GR ● 10 28643.6	KES-GB 17/24 GR ● 10 28644.6	KES-GB 20/24 GR ● 10 28645.6	KES-GB 21/24 GR ● 10 28646.6	KES-GB 32/24 GR ● 10 28647.6
KES-GB 16-1/24 BK ● 10 28643.4	KES-GB 17/24 BK ● 10 28644.4	KES-GB 20/24 BK ● 10 28645.4	KES-GB 21/24 BK ● 10 28646.4	KES-GB 32/24 BK ● 10 28647.4

KES-R 16-1/24 GR ● 10 28653.6	KES-R 17/24 GR ● 10 28654.6	KES-R 20/24 GR ● 10 28655.6	KES-R 21/24 GR ● 10 28656.6	KES-R 32/24 GR ● 10 28657.6
KES-R 16-1/24 BK ● 10 28653.4	KES-R 17/24 BK ● 10 28654.4	KES-R 20/24 BK ● 10 28655.4	KES-R 21/24 BK ● 10 28656.4	KES-R 32/24 BK ● 10 28657.4

2 x 3.2–6.3 9 x 4-7.5 1 x 5.5-10.5 1 x 8-12.5 3 x 12-16.2	4 x 3.2–6.3 2 x 4-7.5 1 x 5.5-10.5 10 x 8-12.5	12 x 3.2–6.3 8 x 5.5-10.5	1 x 3.2–6.3 14 x 4-7.5 4 x 5.5-10.5 2 x 8-12.5	32 x 3.2–6.3
---	---	------------------------------	---	--------------

PA 6.6 GF / elastomer –40 °C to +90 °C IP66 UL 94 V-0 Sheet-metal punch Page 54	PA 6.6 GF / elastomer –40 °C to +90 °C IP66 UL 94 V-0 Sheet-metal punch Page 54	PA 6.6 GF / elastomer –40 °C to +90 °C IP66 UL 94 V-0 Sheet-metal punch Page 54	PA 6.6 GF / elastomer –40 °C to +90 °C IP66 UL 94 V-0 Sheet-metal punch Page 54	PA 6.6 GF / elastomer –40 °C to +90 °C IP66 UL 94 V-0 Sheet-metal punch Page 54
---	---	---	---	---

KES: dimensional drawings / mounting cut-outs cable entries

KES 13/24

Dimension diagram

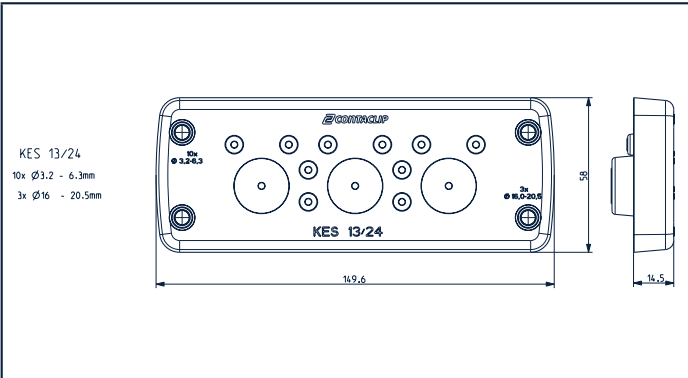

Mounting cut-out

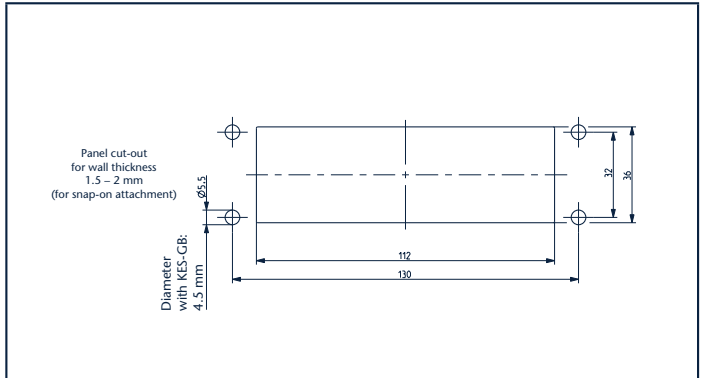

Torque for the frame's mounting screw: 2.5 - 3 Nm

KES 14/24

Dimension diagram

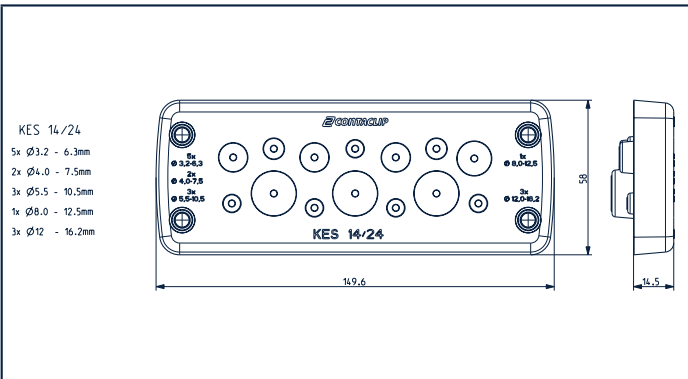

Mounting cut-out

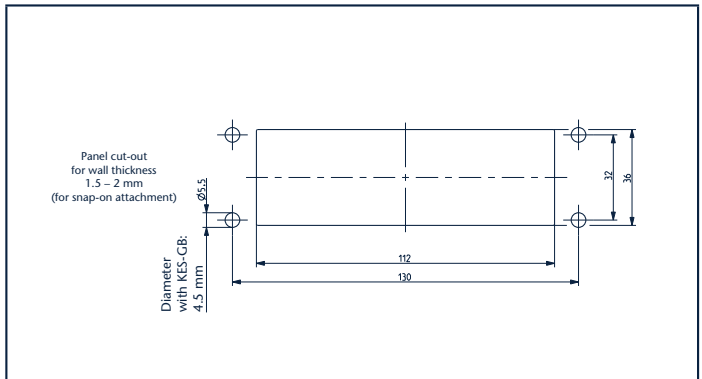

Torque for the frame's mounting screw: 2.5 - 3 Nm

KES 16/24

Dimension diagram

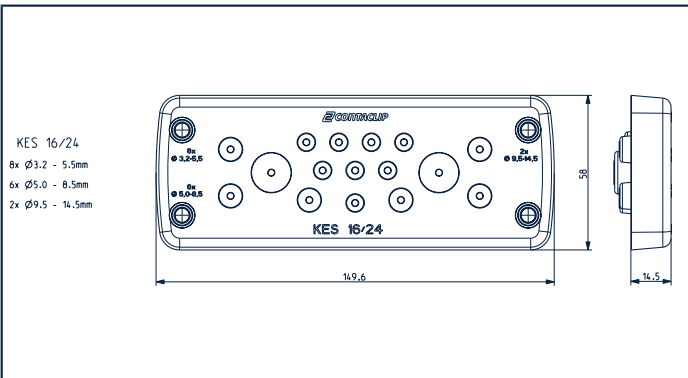

Mounting cut-out

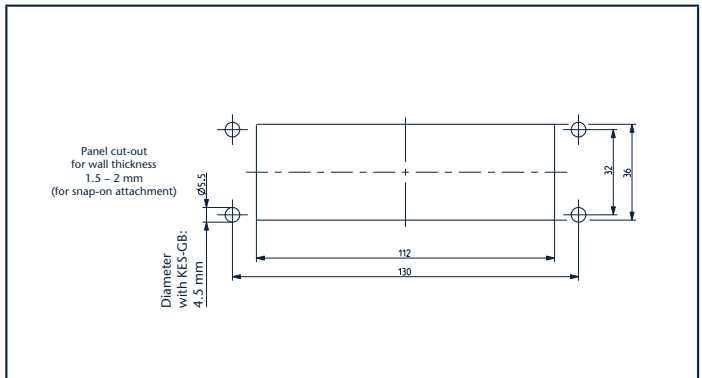

Torque for the frame's mounting screw: 2.5 - 3 Nm

KES 16-1/24

Dimension diagram

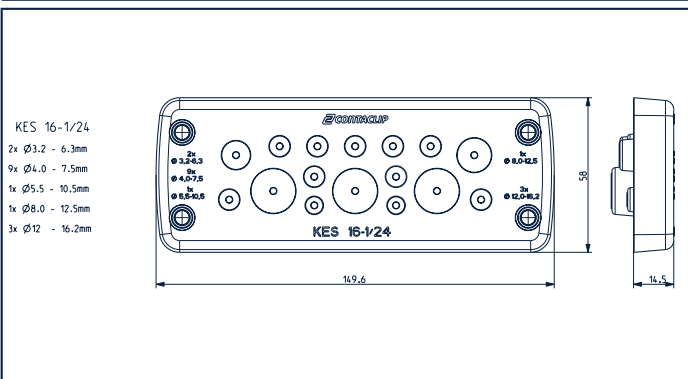

Mounting cut-out

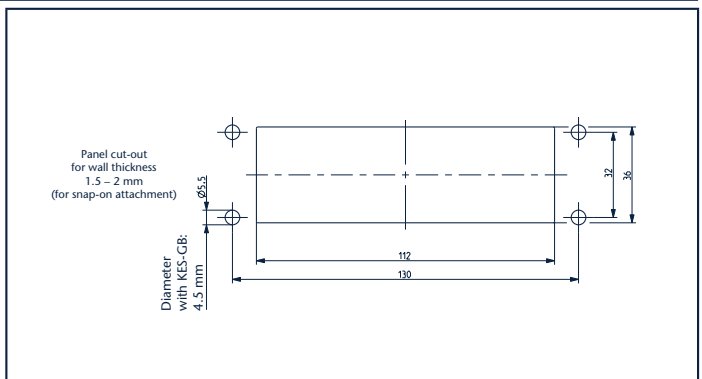

Torque for the frame's mounting screw: 2.5 - 3 Nm

KES 17/24 Dimension diagram Mounting cut-out

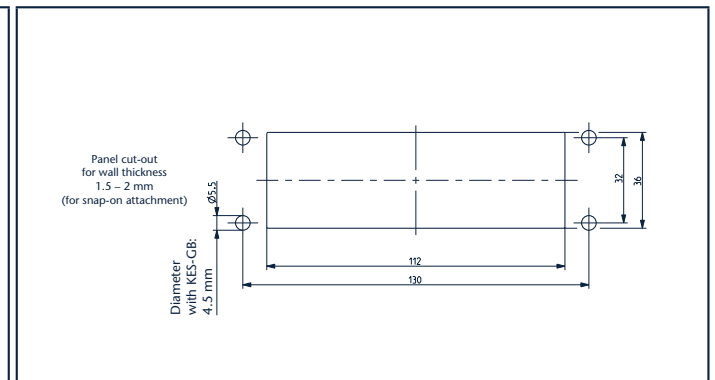
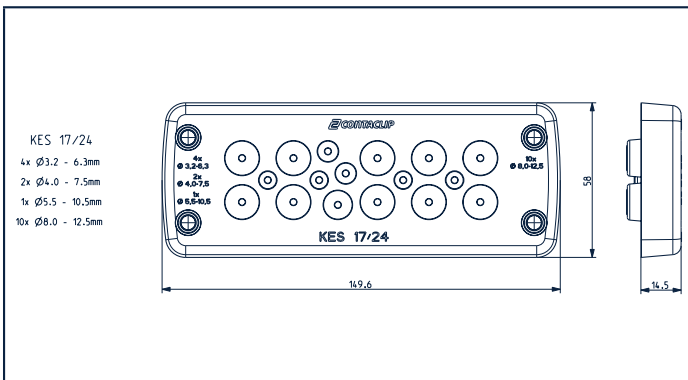

Torque for the frame's mounting screw: 2.5 – 3 Nm

KES 20/24 Dimension diagram Mounting cut-out

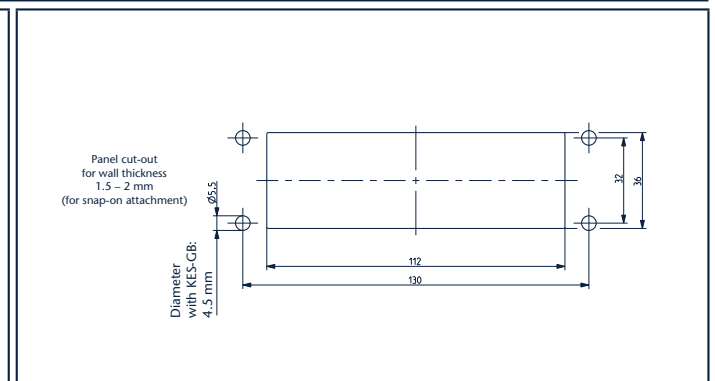
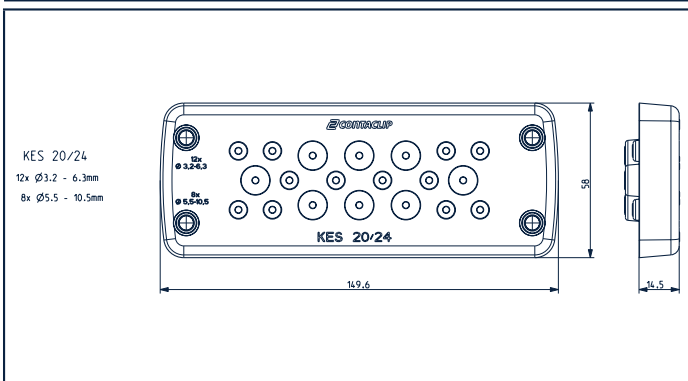

Torque for the frame's mounting screw: 2.5 – 3 Nm

KES 21/24 Dimension diagram Mounting cut-out

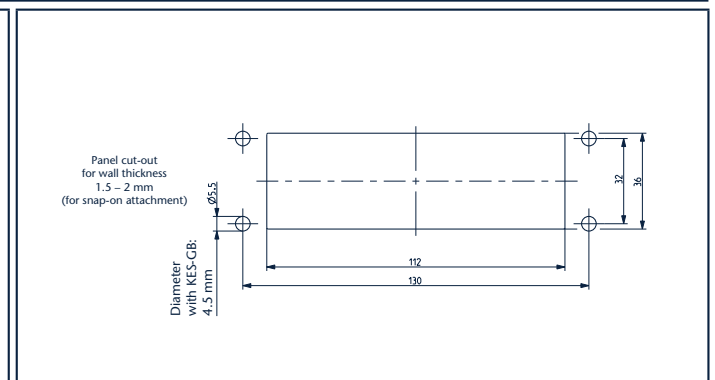
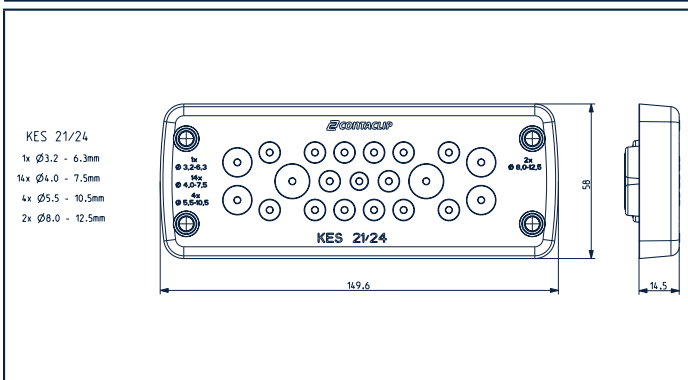

Torque for the frame's mounting screw: 2.5 – 3 Nm

KES 32/24 Dimension diagram Mounting cut-out

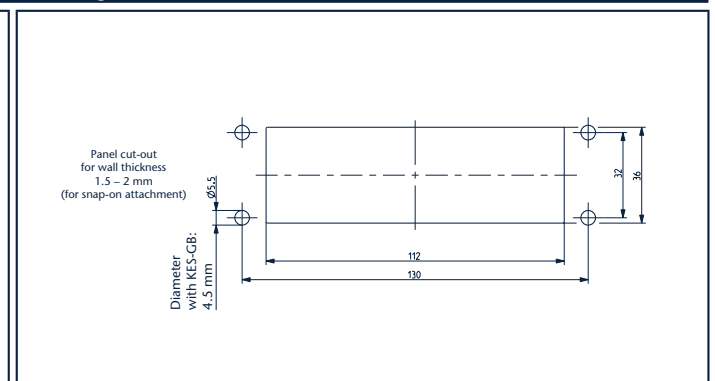
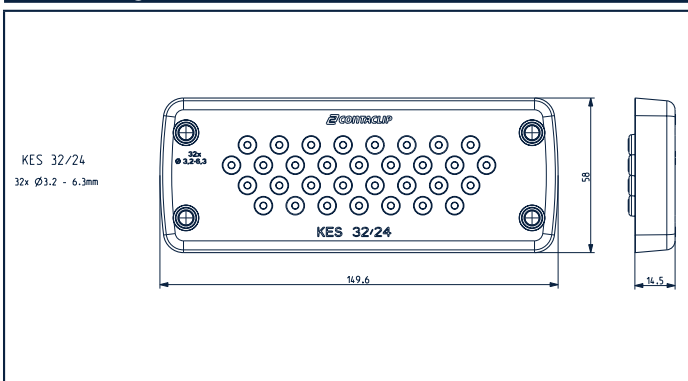

Torque for the frame's mounting screw: 2.5 – 3 Nm

Punching tool

The hydraulic hand pump, when used together with our sheet metal punches, is perfectly suited for quickly producing precise chip-free break-outs.

The sheet metal punches for rectangular format are available for all KDSClick cable entry systems and for all KES cable entry systems. The built-in punch-hole marking tip can be used to punch-mark the drill points clearly for screw-on attachments.

Sheet metal punches are available in circular format for the sizes M20, M25, M32, M40, M50 and M63.

The hydraulic hand pump is also compatible with sheet-metal punches from other popular manufacturers.



Hydraulic hand pump

Hydraulic hand pump

The hydraulic hand pump can be used to punch out openings for various cable feed-through and cable entry systems. The cylinder can be swivelled along 3 axes and rotated 360°, so that the break-outs can also be punched in inconvenient places.



Your advantages

- Easy-to-use format without a tube
- Cylinder can rotate 360° and swivel along 3 axes
- Lightweight aluminium version (weight: 2 kg)
- Can also be used for inconvenient hard-to-reach locations



Features

Punching functionality for max. material thickness

- Round holes 82.0 mm, steel 3 mm, VA 2 mm
- Square holes 68.0 x 68.0 mm, steel 3 mm, VA 2 mm
- Rectangular holes 36.0 x 112.0 mm, steel 3 mm, VA 2 mm

Hydraulic pump



Type	Hydraulic hand pump for sheet-metal punch	
Cat. no.	28679.0	Qty. 1
Included in delivery	1 hydraulic hand pump 1 hydraulic screw 19.0 x 130 mm 1 hydraulic screw 19.0 / 9.5 mm 1 spacer bushing 1 tube of anti-wear paste 1 HSS co-boring drill Multi-step drill, steps: 8-10-11.5-12.5 (M12) 14.5-17.5-21 mm 1 transport box	

Sheet-metal punch BL

Sheet metal punch for the KDSClick, KDS-FP, KDS-FB, KDS-KV and KES cable entry systems. Using the sheet-metal punch, you can produce the desired break-outs, without any chips, in just a few minutes. The built-in punch-hole marking tip can be used to punch-mark the drill points clearly for screw-on attachments. These sheet-metal punches are compatible with all common hydraulic pumps.

Assortment case



Punch, die, draw stud and counter nut in a plastic case

Sheet-metal punch BL		BL KDS-SR 1-4	BL KDS-SR 6/10	BL KDS-SR 8/16
Type		BL KDS-SR 1-4	BL KDS-SR 6/10	BL KDS-SR 8/16
Cat. no.	Qty.	28674.0	28675.0	28676.0
Maximum wall thickness		2.0 mm, for S 235 sheet metal	2.0 mm, for S 235 sheet metal	2.0 mm, for S 235 sheet metal
Dimensions of break-out hole		46 x 46 mm	68.5 x 46 mm	91 x 46 mm
Scope of delivery		Punch, die, draw stud, counter nut, plastic case	Punch, die, draw stud, counter nut, plastic case	Punch, die, draw stud, counter nut, plastic case

Sheet-metal punch BL		BL-VA KDS-SR 1-4	BL-VA KDS-SR 6/10	BL-VA KDS-SR 8/16
Type		BL-VA KDS-SR 1-4	BL-VA KDS-SR 6/10	BL-VA KDS-SR 8/16
Cat. no.	Qty.	28683.0	28684.0	28685.0
Maximum wall thickness		2.0 mm, with stainless steel sheet	2.0 mm, with stainless steel sheet	2.0 mm, with stainless steel sheet
Dimensions of break-out hole		46 x 46 mm	68.5 x 46 mm	91 x 46 mm
Scope of delivery		Punch, die, draw stud, counter nut, plastic case	Punch, die, draw stud, counter nut, plastic case	Punch, die, draw stud, counter nut, plastic case

Sheet-metal punch BL		BL KES	BL KDS-FP2	BL KDS-KV M20
Type		BL KES	BL KDS-FP2	BL KDS-KV M20
Cat. no.	Qty.	28744.0	28745.0	28746.0
Maximum wall thickness		2.0 mm, for S 235 sheet metal	2.0 mm, for S 235 sheet metal	2.0 mm, for S 235 sheet metal
Dimensions of break-out hole		112 x 36 mm	110 x 131 mm	20.4 mm
Scope of delivery		Punch, die, draw stud, counter nut, plastic case	Punch, die, draw stud, counter nut, plastic case	Punch, die

Sheet-metal punch BL		BL-VA KES	BL-VA KDS-FP2	BL-VA KDS-KV M20
Type		BL-VA KES	BL-VA KDS-FP2	BL-VA KDS-KV M20
Cat. no.	Qty.	28752.0	28753.0	28754.0
Maximum wall thickness		2.0 mm, with stainless steel sheet	2.0 mm, with stainless steel sheet	2.0 mm, with stainless steel sheet
Dimensions of break-out hole		112 x 36 mm	110 x 131 mm	20.4 mm
Scope of delivery		Punch, die, draw stud, counter nut, plastic case	Punch, die, draw stud, counter nut, plastic case	Punch, die

Sheet-metal punch BL KDS-KV



Round punches

Sheet-metal punch BL KDS



Rectangular punches

BL KDS-SR 10/24	BL KDS-FB1	BL KDS-FB2	BL KDS-FB3	BL KDS-FB4
BL KDS-SR 10/24	BL KDS-FB1	BL KDS-FB2	BL KDS-FB3	BL KDS-FB4
28677.0 1	28734.0 1	28735.0 1	28736.0 1	28737.0 1
2.0 mm, for S 235 sheet metal	2.0 mm, for S 235 sheet metal	2.0 mm, for S 235 sheet metal	2.0 mm, for S 235 sheet metal	2.0 mm, for S 235 sheet metal
113.5 x 46 mm	46 x 24 mm	68 x 24 mm	89 x 24 mm	111 x 24 mm
Punch, die, draw stud, counter nut, plastic case	Punch, die, draw stud, counter nut, plastic case	Punch, die, draw stud, counter nut, plastic case	Punch, die, draw stud, counter nut, plastic case	Punch, die, draw stud, counter nut, plastic case

BL-VA KDS-SR 10/24	BL-VA KDS-FB1	BL-VA KDS-FB2	BL-VA KDS-FB3	BL-VA KDS-FB4
BL-VA KDS-SR 10/24	BL-VA KDS-FB1	BL-VA KDS-FB2	BL-VA KDS-FB3	BL-VA KDS-FB4
28686.0 1	28729.0 1	28741.0 1	28742.0 1	28743.0 1
2.0 mm, with stainless steel sheet	2.0, with stainless steel sheet	2.0, with stainless steel sheet	2.0, with stainless steel sheet	2.0 mm, with stainless steel sheet
113.5 x 46 mm	46 x 24 mm	68 x 24 mm	89 x 24 mm	111 x 24 mm
Punch, die, draw stud, counter nut, plastic case	Punch, die, draw stud, counter nut, plastic case	Punch, die, draw stud, counter nut, plastic case	Punch, die, draw stud, counter nut, plastic case	Punch, die, draw stud, counter nut, plastic case

BL KDS-KV M25	BL KDS-KV M32	BL KDS-KV M40	BL KDS-KV M50	BL KDS-KV M63
BL KDS-KV M25	BL KDS-KV M32	BL KDS-KV M40	BL KDS-KV M50	BL KDS-KV M63
28747.0 1	28748.0 1	28749.0 1	28750.0 1	28751.0 1
2.0 mm, for S 235 sheet metal	2.0 mm, for S 235 sheet metal	2.0 mm, for S 235 sheet metal	2.0 mm, for S 235 sheet metal	2.0 mm, for S 235 sheet metal
25.4 mm	32.5 mm	40.5 mm	50.5 mm	63.5 mm
Punch, die	Punch, die	Punch, die	Punch, die	Punch, die

BL-VA KDS-KV M25	BL-VA KDS-KV M32	BL-VA KDS-KV M40	BL-VA KDS-KV M50	BL-VA KDS-KV M63
BL-VA KDS-KV M25	BL-VA KDS-KV M32	BL-VA KDS-KV M40	BL-VA KDS-KV M50	BL-VA KDS-KV M63
28755.0 1	28756.0 1	28757.0 1	28758.0 1	28759.0 1
2.0 mm, with stainless steel sheet	2.0, with stainless steel sheet	2.0, with stainless steel sheet	2.0, with stainless steel sheet	2.0 mm, with stainless steel sheet
25.4 mm	32.5 mm	40.5 mm	50.5 mm	63.5 mm
Punch, die	Punch, die	Punch, die	Punch, die	Punch, die

Shield-connection clip

In the field of industrial process engineering, a high degree of interference immunity is required of electrical equipment. This is a critical factor affecting the availability of industrial measurement and control systems.

When constructing low-interference systems, both the cable shielding and the shielded ground are very important. The juncture where the cable shielding connects to the housing ground is a critical point. The connection should be low-ohm and should also feature minimal inductive resistance.

You should be certain that this connection can be established in a practical, simple and quick manner. CONTA-CLIP's SAB/SSAB shielding systems are one of the most comprehensive product portfolios on the market. They offer a perfect solution for any application.



Overview of installation types

Direct mounting



SAB...D
Page 65



SABKM.../D
Page 64

C-rail mounting



SAB...GWP
Page 69

Busbar mounting



SABKM.../SSCH/Z
Page 66



SABKMD.../SSCH/Z
Page 66



SAB
Page 67



SSAB
Page 68

Mounting on the DIN rail



SAB.../F
Page 71



SAB.../MF
Page 72



SABKM.../MF/35/Z
Page 70

Shield-connection bracket SABK

The stripped cable is easily pushed into the SABK shield-connection bracket. The spring force in the bracket then ensures that the shield has a consistently good contact.

The large contact areas ensure excellent dissipation of interference current.

The SABK can be used with the mounting feet for various mounting platforms (e.g. on DIN rail, busbar, or for direct installation).

The SABK for the proper shield diameter is mounted by simply clipping it on (no tools required).



Your advantages

- The spring exerts continuous contact force on the cable shield
- High conductivity
- Very good dissipation of high-frequency interference current
- No tools are required: all sizes can be snapped onto the various mounting feet

Shield-connection bracket		SABK 3	SABK 6	SABK 8
Mounting type		Direct mounting	Direct mounting	Direct mounting
Type		SABK 3	SABK 6	SABK 8
Cat. no.	Qty.	17970.0	17971.0	17972.0
Cable diameter Ø		1.5 – 3 mm	3 – 6 mm	6 – 8 mm
Material		Steel	Steel	Steel

Shield-connection bracket		SABK 11	SABK 16
Mounting type		Direct mounting	Direct mounting
Type		SABK 11	SABK 16
Cat. no.	Qty.	17973.0	17974.0
Cable diameter Ø		8 – 11 mm	11 – 16 mm
Material		Steel	Steel

Shield-connection bracket Multi SABKM

The SABKM Multi shield-connection bracket differs from conventional shielding brackets because of its two specially shaped bracket legs.

These legs produce force on both sides so that a very large cable clamping range is attained. The stripped cable is easily pushed into the SABKM Multi. The spring force in the bracket then ensures that the shield has a consistently good contact.

The large contact surfaces ensure that any interference current is reliably dissipated.



The SABKM Multi can be used with the mounting feet for various mounting platforms (e.g. on DIN rail, busbar, or for direct installation).

The SABKM Multi for the proper shield diameter is mounted by simply clipping it on (no tools required).



Your advantages

- Large clamping range: therefore less individual parts
- The spring force provides consistently good contact to the cable shield
- High conductivity
- Very good dissipation of high-frequency interference current
- No tools are required: all sizes can be snapped onto the various mounting feet

Shield-connection bracket	SABKM 12	SABKM 18
		
Mounting type	Direct mounting	Direct mounting
Type	SABKM 12	SABKM 18
Cat. no.	17975.0	17976.0
Qty.	25	25
Cable diameter Ø	3 – 12 mm	7 – 18 mm
Material	Steel	Steel

Mounting foot MF-SABK/D for direct mounting

The mounting foot for the shield-connection bracket is used as a universal holder for the SABK / SABKM, for clamping diameters from 1.5 to 18 mm. It can be installed directly (e.g. screwed directly onto a mounting plate). The properly sized shield-connection bracket is then simply snapped on and the cable shield is pushed in.



Your advantages

- Direct mounting using M4 screw
- Universal holder for SABK/SABKM, with cable clamping range from 1.5 to 18 mm
- Variable assembly options leads to less product types
- Less parts in your warehouse
- Very compact construction
- Cable tie can be used for strain relief

Installation of the SABKM shield-connection bracket on the MF-SABK/D mounting foot



1. Screw on the mounting foot





2. Snap on your SABK



3. Press in the cable shield



4. Apply strain relief with cable ties

Shield-connection bracket	MF/D M4/Z	MF/D M4
		
Mounting type	Direct mounting	Direct mounting
Description	With strain relief	Without strain relief
Type	MF/D M4/Z	MF/D M4
Cat. no.	17977.0	27217.0
Qty.	10	25
Material	Steel	Steel

Row-mounted foot RMF/D/Z M4 for direct mounting

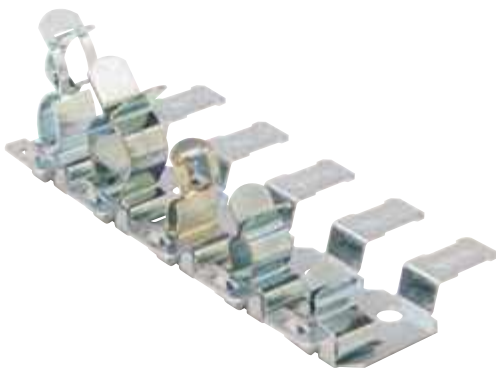

The row-mounted foot for direct installation is a universal holder for up to 12 shield-connection brackets, for cable clamping diameters from 1.5 to 18 mm. The row-mounted foot can be shortened to the desired length by breaking it at one of its breakage points. Either screws or rivets can be used to secure it in position.

Installation of the SABKM shield-connection bracket on the MF-SABK/D mounting foot



Your advantages

- Up to 12 cable shields can be attached to a single row-mounted foot.
- Space-saving installation on the mounting plate
- Universal holders for SABK/SABKM, with variable cable clamping ranges from 1.5 to 18 mm
- Breakage points permit versatile customization for your required number of cables.
- Less parts in your warehouse
- Very compact construction
- Cable tie can be used for strain relief

Shield-connection bracket		Row-mounted foot	
			
Mounting type		Direct mounting	
Description		With strain relief	
Type		RMF/D M4/Z	
Cat. no.		17986.0	10
Material		Steel	

Mounting foot MF-SABK/SSCH for mounting on busbar

The mounting foot for installing on a busbar is used as a universal holder for the shield-connection brackets, for cable diameters from 1.5 to 18 mm. Simply snap the mounting foot onto the 10 x 3 mm busbar. Then snap in the corresponding shield-connection bracket and press in the cable shield.



Your advantages

- Tool-free mounting on a 10 x 3 mm rail
- For shield-connection brackets with a 1.5 – 18 mm clamping range
- Variable assembly options leads to less product types
- Less parts in your warehouse
- Very compact construction
- Cable tie can be used for strain relief

Installation of the SABKM shield-connection bracket on the MF-SABK/SSCH mounting foot



1. Screw on the mounting foot





2. Snap on your SABK



3. Press in the cable shield



4. Apply strain relief with cable ties

Mounting foot		MF-SABK/SSCH/Z	MF-SABK/SSCH
			
Mounting type		Busbar mounting	Busbar mounting
Description		With strain relief	Without strain relief
Type		MF-SABK/SSCH/Z	MF-SABK/SSCH
Cat. no.	Qty.	17979.0	27218.0
Material		Steel	Steel

Mounting foot MF-SABK/35 for mounting on DIN rails

The MF-SABK/35/Z mounting foot (for 35 mm DIN rails) is used as a universal holder for the shield-connection brackets, for cable clamping diameters from 1.5 to 18 mm. Simply snap the mounting foot on the DIN rail. The properly sized shield-connection bracket is then snapped on and the cable shield is pushed in to the shield-connection bracket. The variant with a strain relief bracket provides cable ties to relieve strain.



Your advantages

- Tool-free mounting on 35 mm DIN rail
- Universal holder for SABK/SABKM, with cable clamping range from 1.5 to 18 mm
- Variable assembly options leads to less product types
- Less parts in your warehouse
- Cable tie can be used for strain relief

Installation of the SABKM shield-connection bracket on the MF-SABK/SSCH mounting foot

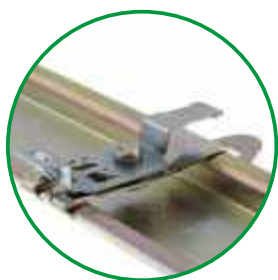

1. Screw on the mounting foot

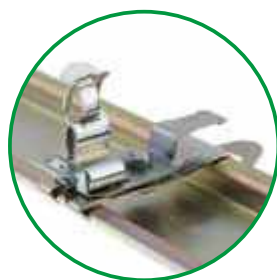



2. Snap on your SABK



3. Press in the cable shield



4. Apply strain relief with cable ties

Mounting foot	MF-SABK/35/Z	MF-SABK/35
		
Mounting type	Mounting on the DIN rail	Mounting on the DIN rail
Description	With strain relief	Without strain relief
Type	MF-SABK/35/Z	MF-SABK/35
Cat. no.	17978.0	27261.0
Qty.	10	10
Material	Steel	Steel

Shield-connection bracket Multi SABK...D for direct mounting

The SABK.../D shield-connection bracket can be installed directly (e.g. screwed directly onto a mounting plate). The cable shield must only be pressed into the SABK in order to establish a reliable contact. The strain relief bracket can be used with a cable tie to relieve strain at the cable sheath.



Your advantages

- Direct mounting using M4 screw
- Very compact construction
- Reduced product types when the Multi shield-connection bracket is used
- Cable tie can be used for strain relief

Shield-connection bracket	SABKM...D	SABKM...D/Z
		
Mounting type	Direct mounting	Direct mounting
Description	Without strain relief	With strain relief
Cable diameter Ø	3 – 12 mm	3 – 12 mm
Type	SABKM 12/D M4	SABKM 12/D M4/Z
<i>Cat. no.</i>	27246.0	17984.0
Qty.	10	10
Drill hole diameter Ø	4.2 mm	4.2 mm
Material	Steel	Steel
Cable diameter Ø	7 – 18 mm	7 – 18 mm
Type	SABKM 18/D M4	SABKM 18/D M4/Z
<i>Cat. no.</i>	27247.0	17985.0
Qty.	10	10
Drill hole diameter Ø	4.2 mm	4.2 mm
Material	Steel	Steel
Cable diameter Ø	17 – 22 mm	17 – 22 mm
Type	SABKM 22/D M4	SABKM 22/D M4/Z
<i>Cat. no.</i>	27248.0	27220.0
Qty.	10	10
Drill hole diameter Ø	4.2 mm	4.2 mm
Material	Steel	Steel
Cable diameter Ø	23 – 29 mm	23 – 29 mm
Type	SABKM 29/D M4	SABKM 29/D M4/Z
<i>Cat. no.</i>	27249.0	27221.0
Qty.	10	10
Drill hole diameter Ø	4.2 mm	4.2 mm
Material	Steel	Steel
Cable diameter Ø	16 – 35 mm	
Type	SABKM 35/D M4	
<i>Cat. no.</i>	27256.0	
Qty.	5	
Drill hole diameter Ø	4.2 mm	
Material	Steel	
Cable diameter Ø	35 – 65 mm	
Type	SABKM 65/D M4	
<i>Cat. no.</i>	27257.0	
Qty.	5	
Drill hole diameter Ø	4.2 mm	
Material	Steel	

Shield-connection clip SAB...D for direct mounting

The SAB.../D shield-connection clip can be used for direct mounting installations. The force on the cable comes from a spring-pressure piece. This regulated pressure ensures a constant optimal contact.



The SAB.../D can be installed with an M4 screw (included in delivery) directly to the mounting plate.

The SAB 8/D M5 shield-connection clip comes with a special feature; it is equipped with a self-cutting M5 SW3 metal screw. As a result, less time is required to mount the clip on the mounting plate, since you only need to drill one 4.2-mm hole through the plate. The hole threads will then be cut into the plate by the screw.



Your advantages

- Tool-free installation
- Quick snap-on or mounting of the shield-connection clip
- Different cable cross-sections can be accommodated by the elastic nature of the spring
- Easy to work with

Shield-connection clip	SAB...D
 	
Mounting type	Direct mounting
Type	SAB 8/D
<i>Cat. no.</i>	1549.0
Qty.	10
Cable diameter Ø	3 – 8 mm
Screw	M 4
Material	Steel
Type	SAB 8/D/M5
<i>Cat. no.</i>	1526.0
Qty.	10
Cable diameter Ø	3 – 8 mm
Screw	M 4
Material	Steel
Type	SAB 13,5/D
<i>Cat. no.</i>	1550.0
Qty.	10
Cable diameter Ø	4 – 13.5 mm
Screw	M 4
Material	Steel
Type	SAB 20/D
<i>Cat. no.</i>	1551.0
Qty.	10
Cable diameter Ø	10 – 20 mm
Screw	M 4
Material	Steel
Type	SAB 32/D
<i>Cat. no.</i>	17361.0
Qty.	10
Cable diameter Ø	15 – 32 mm
Screw	M 4
Material	Steel





Shield-connection bracket Multi SABKM.../SSCH M4 on mounting foot for busbar mounting

The Multi shield-connection clamp (on mounting foot) can be snapped onto a 10x3mm busbar without using any tools.
The cable shield must only be pressed into the Multi shield-connection bracket in order to establish a reliable contact.
The strain relief clip can be used with a cable tie to relieve strain.

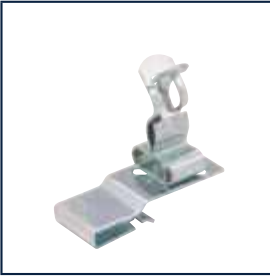

Your advantages

- No tools required to mount on a 10 x 3 mm busbar
- Extremely compact construction
- Cable tie can be used for strain relief

Shield-connection bracket	SABKM.../SSCH	SABKM.../SSCH	SABKMD.../SSCH	SABKMD.../SSCH/Z
				
Mounting type	Busbar mounting	Busbar mounting	Busbar mounting	Busbar mounting
Description	Without strain relief	With strain relief	Without strain relief	With strain relief
Type	SABKM 12/SSCH	SABKM 12/SSCH/Z	SABKD 1.5-3/SSCH	SABKD 1.5-3/SSCH/Z
Cat. no.	27224.0	17982.0	27250.0	27259.0
Qty.	10	10	10	10
Cable diameter Ø	3 – 12 mm	3 – 12 mm	1.5 – 3 mm	1.5 – 3 mm
Material	Steel	Steel	Steel	Steel
Type	SABKM 18/SSCH	SABKM 18/SSCH/Z	SABKD 3-6/SSCH	SABKD 3-6/SSCH/Z
Cat. no.	27225.0	17983.0	27251.0	27260.0
Qty.	10	10	10	10
Cable diameter Ø	7 – 18 mm	7 – 18 mm	3 – 6 mm	3 – 6 mm
Material	Steel	Steel	Steel	Steel
Type	SABKM 22/SSCH	SABKM 22/SSCH/Z	SABKD 6-8/SSCH	SABKD 6-8/SSCH/Z
Cat. no.	27226.0	27228.0	27252.0	27254.0
Qty.	10	10	10	10
Cable diameter Ø	17 – 22 mm	17 – 22 mm	6 – 8 mm	6 – 8 mm
Material	Steel	Steel	Steel	Steel
Type	SABKM 29/SSCH	SABKM 29/SSCH/Z	SABKMD 3-12/SSCH	SABKMD 3-12/SSCH/Z
Cat. no.	27227.0	27262.0	27253.0	27255.0
Qty.	10	10	10	10
Cable diameter Ø	23 – 29 mm	23 – 29 mm	3 – 12 mm	3 – 12 mm
Material	Steel	Steel	Steel	Steel



Shield-connection clip SAB

The SAB can be mounted on a busbar. After connecting the wiring, the shield-connection clip is mounted by simply swivelling in the SAB clip onto the busbar. The force on the cable comes from a spring-pressure piece. This regulated pressure ensures a constant optimal contact. This makes the SAB shield-connection clip very convenient to wire. Depending on the length of the terminal blocks, two or more SH/SAB busbar holders should be used. These mechanically connect the front busbar with the DIN rail (holder).



Your advantages

- Quick snap-on or mounting of the shield-connection clip
- Different cable cross-sections can be accommodated by the elastic nature of the spring
- Easy to work with

Shield-connection clip	SAB
	
Mounting type	Busbar mounting
Type	SAB 8
<i>Cat. no.</i>	<i>1527.0</i>
Qty.	10
Cable diameter Ø	3 – 8 mm
Material	Steel
Type	SAB 13.5
<i>Cat. no.</i>	<i>1528.0</i>
Qty.	10
Cable diameter Ø	4 – 13.5 mm
Material	Steel
Type	SAB 20
<i>Cat. no.</i>	<i>1529.0</i>
Qty.	10
Cable diameter Ø	10 – 20 mm
Material	Steel

Shield-connection clip SSAB for mounting on busbar

The SSAB can be mounted on a busbar. After wiring the terminal block, the shield-connection clip is mounted by simply swivelling in and tightening the knurled thumb screw. This makes the SSAB screw-shield-connection clip very convenient to wire. Depending on the length of the terminal blocks, two or more SH/SAB busbar holders should be used. These mechanically connect the front busbar with the DIN rail (holder). The SH1 busbar holders are used where a shield-connection system must be mounted directly onto a panel rather than a DIN rail. The 10 x 3 mm busbars can be easily and quickly snapped on to these supports. In both cases, the contact with the earth or ground potential can be established with a ZB clamping yoke.



Your advantages

- Screw-on clip for simple retrofitting
- Knurled thumb screw, so no tools required
- Easy to work with
- Large shield surface
- Secure contact

Shield-connection clip for busbar mounting

SSAB



Mounting type	Busbar mounting
Type	SSAB 5
<i>Cat. no.</i>	<i>3694.0</i>
Qty.	10
Cable diameter Ø	2 – 5 mm
Torque, Nm	0.4
Material	Steel
Type	SSAB 8
<i>Cat. no.</i>	<i>3695.0</i>
Qty.	10
Cable diameter Ø	3 – 8 mm
Torque, Nm	0.6
Material	Steel
Type	SSAB 14
<i>Cat. no.</i>	<i>3696.0</i>
Qty.	10
Cable diameter Ø	3 – 14 mm
Torque, Nm	0.8
Material	Steel
Type	SSAB 20
<i>Cat. no.</i>	<i>3697.0</i>
Qty.	10
Cable diameter Ø	3 – 20 mm
Torque, Nm	0.8
Material	Steel
Type	SSAB 28
<i>Cat. no.</i>	<i>3698.0</i>
Qty.	10
Cable diameter Ø	5 – 28 mm
Torque, Nm	0.8
Material	Steel
Type	SSAB 35
<i>Cat. no.</i>	<i>3699.0</i>
Qty.	10
Cable diameter Ø	20 – 35 mm
Torque, Nm	1.8
Material	Steel

Shield-connection clip for the C-rail SAB.../GWP

The SAB.../GWP can be mounted on a C rail. The SAB.../GWP is attached to the threaded plate with an Allen (hex socket) screw. The force on the cable comes from a spring-pressure piece. This regulated pressure ensures a constant optimal contact with the DIN rail.



Your advantages

- Shield-connection clip is quickly mounted
- Different cable cross-sections can be accommodated by the elastic nature of the spring
- Easy to work with

Shield-connection clip for C-rail



SAB.../GWP



Mounting type	C-rail mounting	
Type	SAB 8/GWP	
<i>Cat. no.</i>	Qty.	17356.0 10
Cable diameter Ø	3 – 8 mm	
Material	Steel	
Type	SAB 13.5/GWP	
<i>Cat. no.</i>	Qty.	17357.0 10
Cable diameter Ø	4 – 13.5 mm	
Material	Steel	
Type	SAB 20/GWP	
<i>Cat. no.</i>	Qty.	17358.0 10
Cable diameter Ø	10 – 20 mm	
Material	Steel	
Type	SAB 32/GWP	
<i>Cat. no.</i>	Qty.	17359.0 10
Cable diameter Ø	15 – 32 mm	
Material	Steel	

Shield-connection bracket SABKM.../MF/35 for DIN rail mounting

The Multi shield-connection bracket (on mounting foot) can be snapped onto a 35mm DIN rail without using any tools. The cable shield must only be pressed into the Multi shield-connection bracket in order to establish a reliable contact. The strain relief clip can be used with a cable tie to relieve strain.



Your advantages

- Simple tool-free installation
- Spring force provides consistently good contact to the cable shield
- Very good dissipation of high-frequency interference current
- Cable tie can be used for strain relief

Shield-connection bracket	SABK .../MF/35	SABK .../MF/35/Z
		
Mounting type	Mounting on the DIN rail	Mounting on the DIN rail
Description	Without strain relief	With strain relief
Cable diameter Ø	1.5 – 3 mm	1.5 – 3 mm
Type	SABK 3/MF/35	SABK 3/MF/35/Z
Cat. no.	27229.0	27240.0
Qty.	10	10
Cable diameter Ø	3 – 6 mm	3 – 6 mm
Type	SABK 6/MF/35	SABK 6/MF/35/Z
Cat. no.	27230.0	27241.0
Qty.	10	10
Cable diameter Ø	6 – 8 mm	6 – 8 mm
Type	SABK 8/MF/35	SABK 8/MF/35/Z
Cat. no.	27231.0	27242.0
Qty.	10	10
Cable diameter Ø	8 – 11 mm	8 – 11 mm
Type	SABK 11/MF/35	SABK 11/MF/35/Z
Cat. no.	27232.0	27243.0
Qty.	10	10
Cable diameter Ø	11 – 16 mm	11 – 16 mm
Type	SABK 16/MF/35	SABK 16/MF/35/Z
Cat. no.	27233.0	27244.0
Qty.	10	10
Cable diameter Ø	17 – 22 mm	17 – 22 mm
Type	SABK 22/MF/35	SABK 22/MF/35/Z
Cat. no.	27234.0	27245.0
Qty.	10	10
Cable diameter Ø	23 – 29 mm	
Type	SABK 29/MF/35	
Cat. no.	27235.0	
Qty.	10	
Cable diameter Ø	30 – 37 mm	
Type	SABK 37/MF/35	
Cat. no.	27236.0	
Qty.	10	
Cable diameter Ø	3 – 12 mm	3 – 12 mm
Type	SABKM 12/MF/35	SABKM 12/MF/35/Z
Cat. no.	27237.0	17980.0
Qty.	10	10
Cable diameter Ø	7 – 18 mm	7 – 18 mm
Type	SABKM 18/MF/35	SABKM 18/MF/35/Z
Cat. no.	27238.0	17981.0
Qty.	10	10
Cable diameter Ø	16 – 35 mm	
Type	SABKM 35/MF/35	
Cat. no.	27239.0	
Qty.	5	
Cable diameter Ø	35 – 65 mm	
Type	SABKM 65/MF/35	
Cat. no.	27258.0	
Qty.	5	





Shield-connection clip SAB...F for DIN rail mounting

The SAB../F shield-connection clip can be mounted on a DIN rail. The force on the cable comes from a spring-pressure piece. This regulated pressure ensures a constant optimal contact. The SAB../F can be mounted directly to the TS 35 rail using the clamping foot and a mounting screw.



Your advantages

- Shield-connection clip is quickly mounted
- Different cable cross-sections can be accommodated by the elastic nature of the spring
- Easy to work with

Shield-connection clip	SAB 8/F	SAB 13,5/F	SAB 20/F
			
Mounting type	Mounting on the DIN rail	Mounting on the DIN rail	Mounting on the DIN rail
Cable diameter Ø	3 – 8 mm	4 – 13.5 mm	10 – 20 mm
Type	SAB 8/F	SAB 13,5/F	SAB 20/F
Cat. no.	1571.0	1572.0	1573.0
Qty.	10	10	10
Dimensions	18.5 x 13 x 26.5	22 x 19.5 x 32.5	27 x 13 x 26.5
Material	Steel	Steel	Steel

Shield-connection clip SAB...MF for DIN rail mounting

The SAB.../MF/35 can be installed on a DIN rail. The SAB.../MF/35 is snapped on directly via the internal-spring MF/35 mounting foot without using any tools. The force on the cable comes from a spring-pressure piece. This regulated pressure ensures a constant optimal contact with the DIN rail.



Your advantages

- Simple tool-free installation
- Different cable cross-sections can be accommodated by the elastic nature of the spring
- Easy to work with
- /S version can be rotated and fixed in position using the fastening screw

Shield-connection clip	SAB...MF	SAB...MF/35/S
		
Mounting type	Mounting on the DIN rail	Mounting on the DIN rail
Cable diameter Ø	3 – 8 mm	3 – 8 mm
Type	SAB 8/MF/35	SAB 8/MF/35/S
<i>Cat. no.</i>	<i>17038.0</i>	<i>17340.0</i>
Qty.	10	10
Dimensions	18.5 x 13 x 26.5	18.5 x 13 x 26.5
Material	Steel	Steel
Cable diameter Ø	4 – 13.5 mm	4 – 13.5 mm
Type	SAB 13.5/MF/35	SAB 13.5/MF/3/S5
<i>Cat. no.</i>	<i>17039.0</i>	<i>17341.0</i>
Qty.	10	5
Dimensions	22 x 19.5 x 32.5	22 x 19.5 x 32.5
Material	Steel	Steel
Cable diameter Ø	10 – 20 mm	10 – 20 mm
Type	SAB 20/MF/35	SAB 20/MF/35/S
<i>Cat. no.</i>	<i>17040.0</i>	<i>17342.0</i>
Qty.	10	10
Dimensions	27 x 24.5 x 40.5	27 x 24.5 x 40.5
Material	Steel	Steel
Cable diameter Ø	15 – 32 mm	15 – 32 mm
Type	SAB 32/MF/35	SAB 32/MF/35/S
<i>Cat. no.</i>	<i>17363.0</i>	<i>17343.0</i>
Qty.	10	10
Dimensions	53.2 x 33 x 71.5	53.2 x 33 x 71.5
Material	Steel	Steel





Busbar holder

Busbar holders are used for mounting all shield-connection clips with 10x3mm busbars. These can be mounted quickly and flexibly according to your requirements. The SH1 busbar holders are used where a shield-connection system must be mounted directly onto a panel rather than a DIN rail. The 10x3mm busbars can be easily and quickly snapped on to these supports.

The SH/SAB busbar holders mechanically connect the preceding busbar with the DIN rail. Thus, the shield-connection clip can easily be extended directly to the terminal strip.

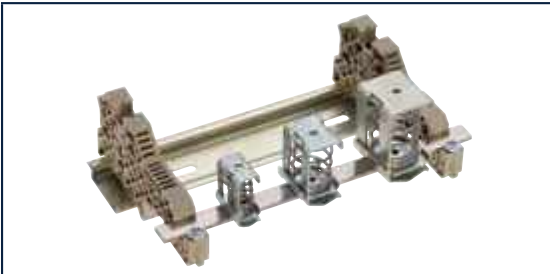
The ES 35/K/ST end stops have a built-in support that makes it easy to mount 10x3mm busbars directly above a 35mm DIN rail.

Depending on the length, two or more holders may be used. The contact to the earth/ground potential is always established using a ZB clamping yoke.

Busbar holder			SH 1	SH SAB	ES 35/K/ST
					
Type/colour			SH 1 BG	SH SAB BG	ES 35/K/ST BG
<i>Cat. no.</i>			2318.2	1530.2	2828.0
Qty.			20	10	50
Dimensions			24 x 24 x 23.7	50 x 9.5 x 98	50 x 9.5 x 44
Material of cap/holder			PA 6.6 V2	PA 6.6 V2	PA 6.6 V2
Accessories					
Mounting screw BS			BS M 4x8		
<i>Cat. no.</i>			2262.0		
Qty.			20		
Busbar	Ssch	Copper	Ssch 10 x 3 CU	Ssch 10 x 3 CU	Ssch 10 x 3 CU
<i>Cat. no.</i>			2129.0	2129.0	2129.0
Qty.			1 m	1 m	1 m
Busbar	Ssch	Brass	Ssch 10 x 3 Ms	Ssch 10 x 3 Ms	Ssch 10 x 3 Ms
<i>Cat. no.</i>			2128.0	2128.0	2128.0
Qty.			1 m	1 m	1 m

Types and catalogue numbers, alphabetic

Type	Cat. no.	Page	Type	Cat. no.	Page	Type	Cat. no.	Page
B			KDS-DE 3-4 GR	28564.6	42	KDS-DEG 25-26 GR	28587.6	42
BL KDS-KV M20	28746.0	54	KDS-DE 3x5-6 BK	28687.4	43	KDS-DEG 26-27 BK	28547.4	43
BL KDS-KV M25	28747.0	55	KDS-DE 3x5-6 GR	28688.6	42	KDS-DEG 26-27 GR	28588.6	42
BL KDS-KV M32	28748.0	55	KDS-DE 4-5 BK	28524.4	43	KDS-DEG 27-28 BK	28548.4	43
BL KDS-KV M40	28749.0	55	KDS-DE 4-5 GR	28565.6	42	KDS-DEG 27-28 GR	28589.6	42
BL KDS-KV M50	28750.0	55	KDS-DE 4x2-3 BK	28557.4	43	KDS-DEG 28-29 BK	28549.4	43
BL KDS-KV M63	28751.0	55	KDS-DE 4x2-3 GR	28597.6	42	KDS-DEG 28-29 GR	28590.6	42
BL KDS-FB1	28734.0	55	KDS-DE 4x3-4 BK	28558.4	43	KDS-DEG 29-30 BK	28550.4	43
BL KDS-FB2	28735.0	55	KDS-DE 4x3-4 GR	28598.6	42	KDS-DEG 29-30 GR	28591.6	42
BL KDS-FB3	28736.0	55	KDS-DE 4x5 BK	28672.4	43	KDS-DEG 30-31 BK	28551.4	43
BL KDS-FB4	28737.0	55	KDS-DE 4x5 GR	28673.6	42	KDS-DEG 30-31 GR	28592.6	42
BL KDS-FP2	28745.0	54	KDS-DE 4x4.5 BK	28681.4	43	KDS-DEG 31-32 BK	28552.4	43
BL KDS-SR 1-4	28674.0	54	KDS-DE 4x4.5 GR	28606.6	42	KDS-DEG 31-32 GR	28593.6	42
BL KDS-SR 10/24	28677.0	55	KDS-DE 4x6 BK	28763.4	43	KDS-DEG 32-33 BK	28601.4	43
BL KDS-SR 6/10	28675.0	54	KDS-DE 4x6 GR	28762.6	42	KDS-DEG 32-33 GR	28594.6	42
BL KDS-SR 8/16	28676.0	54	KDS-DE 5-6 BK	28525.4	43	KDS-DEG/B BK	28534.4	43
BL KES	28744.0	54	KDS-DE 5-6 GR	28566.6	42	KDS-DEG/B GR	28575.6	42
BL-VA KDS-KV M20	28754.0	54	KDS-DE 6-7 BK	28526.4	43	KDS-DEG/K 7-24 BK	28554.4	43
BL-VA KDS-KV M25	28754.0	55	KDS-DE 6-7 GR	28567.6	42	KDS-EMV-SAB 1-4	28623.0	41
BL-VA KDS-KV M32	28756.0	55	KDS-DE 7-8 BK	28527.4	43	KDS-EMV-SAB 10/24	28626.0	41
BL-VA KDS-KV M40	28757.0	55	KDS-DE 7-8 GR	28568.6	42	KDS-EMV-SAB 6/10	28624.0	41
BL-VA KDS-KV M50	28758.0	55	KDS-DE 8-9 BK	28528.4	43	KDS-EMV-SAB 8/16	28625.0	41
BL-VA KDS-KV M63	28759.0	55	KDS-DE 8-9 GR	28569.6	42	KDS-FP 2x10/24 BK	28660.4	30
BL-VA KDS-FB1	28729.0	55	KDS-DE 9-10 BK	28529.4	43	KDS-FP 3x10/24 BK	28661.4	30
BL-VA KDS-FB2	28741.0	55	KDS-DE 9-10 GR	28570.6	42	KDS-FP-IVR OG	28664.3	30
BL-VA KDS-FB3	28742.0	55	KDS-DE-FB1/A GR	28713.6	16	KDS-GM 20 BK	28616.4	38
BL-VA KDS-FB4	28743.0	55	KDS-DE-FB1/B GR	28714.6	16	KDS-GM 25 BK	28617.4	38
BL-VA KDS-FP2	28753.0	54	KDS-DE-FB1/C GR	28715.6	16	KDS-GM 32 BK	28618.4	38
BL-VA KDS-SR 1-4	28683.0	54	KDS-DE-FB1/D GR	28716.6	16	KDS-GM 40 BK	28619.4	39
BL-VA KDS-SR 10/24	28686.0	55	KDS-DE-FB1/E GR	28717.6	16	KDS-GM 50 BK	28620.4	39
BL-VA KDS-SR 6/10	28684.0	54	KDS-DE-FB1/F GR	28718.6	16	KDS-GM 63 BK	28621.4	39
BL-VA KDS-SR 8/16	28685.0	54	KDS-DE-FB2/A GR	28719.6	16	KDS-Inlay 1 BK	28516.4	24
BL-VA KES	28752.0	54	KDS-DE-FB2/B GR	28720.6	16	KDS-Inlay 2 BK	28517.4	24
			KDS-DE-FB2/C GR	28721.6	16	KDS-Inlay 4 BK	28518.4	24
E			KDS-DE-FB2/D GR	28722.6	16	KDS-Inlay 6 BK	28519.4	24
ES 35/K/ST BG	2828.0	73	KDS-DE-FB2/E GR	28723.6	16	KDS-IVR 1-4 BK	28507.4	24
			KDS-DE-FB2/F GR	28724.6	16	KDS-IVR 10/24 BK	28505.4	24
H			KDS-DE-FB3/A GR	28725.6	16	KDS-IVR 6/10 BK	28501.4	24
Hydraulic hand pump for sheet-metal punch	28679.0	53	KDS-DE-FB3/B GR	28726.6	16	KDS-IVR 8/16 BK	28503.4	24
			KDS-DE-FB4/A GR	28727.6	16	KDS-KV M20 BK	28610.4	38
K			KDS-DE-FB4/B GR	28728.6	16	KDS-KV M25 BK	28611.4	38
KDS BW 1	28622.0	40	KDS-DE/1XASI BK	28559.4	43	KDS-KV M32 BK	28612.4	38
KDS-DE 1.5-2 BK	28521.4	43	KDS-DE/1XASI GR	28599.6	42	KDS-KV M40 BK	28613.4	39
KDS-DE 1.5-2 GR	28562.6	42	KDS-DE/2XASI BK	28560.4	43	KDS-KV M50 BK	28614.4	39
KDS-DE 10-11 BK	28530.4	43	KDS-DE/2XASI GR	28600.6	42	KDS-KV M63 BK	28615.4	39
KDS-DE 10-11 GR	28571.6	42	KDS-DE/B BK	28520.4	43	KDS-Set 1-4 BK	28602.4	24
KDS-DE 11-12 BK	28531.4	43	KDS-DE/B GR	28561.6	42	KDS-Set 10/24 BK	28605.4	24
KDS-DE 11-12 GR	28572.6	42	KDS-DE/K 2-11 BK	28553.4	43	KDS-Set 6/10 BK	28603.4	24
KDS-DE 12-13 BK	28532.4	43	KDS-DEG 14-15 BK	28535.4	43	KDS-Set 8/16 BK	28604.4	24
KDS-DE 12-13 GR	28573.6	42	KDS-DEG 14-15 GR	28576.6	42	KDS-SR 1-4 BK	28506.4	24
KDS-DE 13-14 BK	28533.4	43	KDS-DEG 15-16 BK	28536.4	43	KDS-SR 10/24 BK	28504.4	24
KDS-DE 13-14 GR	28574.6	42	KDS-DEG 15-16 GR	28577.6	42	KDS-SR 6/10 BK	28500.4	24
KDS-DE 14-15 BK	28608.4	43	KDS-DEG 16-17 BK	28537.4	43	KDS-SR 8/16 BK	28502.4	24
KDS-DE 14-15 GR	28609.6	42	KDS-DEG 16-17 GR	28578.6	42	KDS-SR-FB1/A BK	28700.4	12
KDS-DE 15-16 BK	28670.4	43	KDS-DEG 17-18 BK	28538.4	43	KDS-SR-FB2/A BK	28701.4	12
KDS-DE 15-16 GR	28671.6	42	KDS-DEG 17-18 GR	28579.6	42	KDS-SR-FB2/B BK	28702.4	12
KDS-DE 2-3 BK	28522.4	43	KDS-DEG 18-19 BK	28539.4	43	KDS-SR-FB3/A BK	28703.4	13
KDS-DE 2-3 GR	28563.6	42	KDS-DEG 18-19 GR	28580.6	42	KDS-SR-FB3/B BK	28704.4	13
KDS-DE 2x4-5 BK	28555.4	43	KDS-DEG 19-20 BK	28540.4	43	KDS-SR-FB3/C BK	28705.4	13
KDS-DE 2x4-5 GR	28595.6	42	KDS-DEG 19-20 GR	28581.6	42	KDS-SR-FB3/D BK	28706.4	13
KDS-DE 2x5-6 BK	28556.4	43	KDS-DEG 20-21 BK	28541.4	43	KDS-SR-FB4/A BK	28707.4	12
KDS-DE 2x5-6 GR	28596.6	42	KDS-DEG 20-21 GR	28582.6	42	KDS-SR-FB4/B BK	28708.4	12
KDS-DE 2x6.5 BK	28682.4	43	KDS-DEG 21-22 BK	28542.4	43	KDS-SR-FB4/C BK	28709.4	12
KDS-DE 2x6.5 GR	28607.6	42	KDS-DEG 21-22 GR	28583.6	42	KDS-SR-FB4/D BK	28710.4	13
KDS-DE 2x7 BK	28689.4	43	KDS-DEG 22-23 BK	28543.4	43	KDS-SR-FB4/E BK	28711.4	13
KDS-DE 2x7 GR	28690.6	42	KDS-DEG 22-23 GR	28584.6	42	KDS-SR-FB4/F BK	28712.4	13
KDS-DE 2x8 BK	28691.4	43	KDS-DEG 23-24 BK	28544.4	43	KES 13/24 BK	28630.4	48
KDS-DE 2x8 GR	28692.6	42	KDS-DEG 23-24 GR	28585.6	42	KES 13/24 GR	28630.6	48
KDS-DE 3-4 BK	28523.4	43	KDS-DEG 24-25 BK	28545.4	43	KES 14/24 BK	28631.4	48
			KDS-DEG 24-25 GR	28586.6	42	KES 14/24 GR	28631.6	48
			KDS-DEG 25-26 BK	28546.4	43	KES 16-1/24 BK	28633.4	49

Type	Cat. no.	Page	Type	Cat. no.	Page	Type	Cat. no.	Page
KES 16-1/24 GR	28633.6	49	SAB 8/F	1571.0	71			
KES 16/24 BK	28632.4	48	SAB 8/GWP	17356.0	69			
KES 16/24 GR	28632.6	48	SAB 8/MF/35	17038.0	72			
KES 17/24 BK	28634.4	49	SAB 8/MF/35/S	17340.0	72			
KES 17/24 GR	28634.6	49	SABK 11	17973.0	58			
KES 20/24 BK	28635.4	49	SABK 11/MF/35	27232.0	70			
KES 20/24 GR	28635.6	49	SABK 11/MF/35/Z	27243.0	70			
KES 21/24 BK	28636.4	49	SABK 16	17974.0	58			
KES 21/24 GR	28636.6	49	SABK 16/MF/35	27233.0	70			
KES 32/24 BK	28637.4	49	SABK 16/MF/35/Z	27244.0	70			
KES 32/24 GR	28637.6	49	SABK 22/MF/35	27234.0	70			
KES-GB 13/24 BK	28640.4	48	SABK 22/MF/35/Z	27245.0	70			
KES-GB 13/24 GR	28640.6	48	SABK 29/MF/35	27235.0	70			
KES-GB 14/24 BK	28641.4	48	SABK 3	17970.0	58			
KES-GB 14/24 GR	28641.6	48	SABK 3/MF/35	27229.0	70			
KES-GB 16-1/24 BK	28643.4	49	SABK 3/MF/35/Z	27240.0	70			
KES-GB 16-1/24 GR	28643.6	49	SABK 37/MF/35	27236.0	70			
KES-GB 16/24 BK	28642.4	48	SABK 6	17971.0	58			
KES-GB 16/24 GR	28642.6	48	SABK 6/MF/35	27230.0	70			
KES-GB 17/24 BK	28644.4	49	SABK 6/MF/35/Z	27241.0	70			
KES-GB 17/24 GR	28644.6	49	SABK 8	17972.0	58			
KES-GB 20/24 BK	28645.4	49	SABK 8/MF/35	27231.0	70			
KES-GB 20/24 GR	28645.6	49	SABK 8/MF/35/Z	27242.0	70			
KES-GB 21/24 BK	28646.4	49	SABKD 1,5-3/SSCH/Z	27259.0	66			
KES-GB 21/24 GR	28646.6	49	SABKD 3-6/SSCH/Z	27260.0	66			
KES-GB 32/24 BK	28647.4	49	SABKM 12	17975.0	59			
KES-GB 32/24 GR	28647.6	49	SABKM 12/D M4	27246.0	64			
KES-R 13/24 BK	28650.4	48	SABKM 12/D M4/Z	17984.0	64			
KES-R 13/24 GR	28650.6	48	SABKM 12/MF/35	27237.0	70			
KES-R 14/24 BK	28651.4	48	SABKM 12/MF/35/Z	17980.0	70			
KES-R 14/24 GR	28651.6	48	SABKM 12/SSCH	27224.0	66			
KES-R 16-1/24 BK	28653.4	49	SABKM 12/SSCH/Z	17982.0	66			
KES-R 16-1/24 GR	28653.6	49	SABKM 18	17976.0	59			
KES-R 16/24 BK	28652.4	48	SABKM 18/D M4	27247.0	64			
KES-R 16/24 GR	28652.6	48	SABKM 18/D M4/Z	17985.0	64			
KES-R 17/24 BK	28654.4	49	SABKM 18/MF/35	27238.0	70			
KES-R 17/24 GR	28654.6	49	SABKM 18/MF/35/Z	17981.0	70			
KES-R 20/24 BK	28655.4	49	SABKM 18/SSCH	27225.0	66			
KES-R 20/24 GR	28655.6	49	SABKM 18/SSCH/Z	17983.0	66			
KES-R 21/24 BK	28656.4	49	SABKM 22/D M4	27248.0	64			
KES-R 21/24 GR	28656.6	49	SABKM 22/D M4/Z	27220.0	64			
KES-R 32/24 BK	28657.4	49	SABKM 22/SSCH	27226.0	66			
KES-R 32/24 GR	28657.6	49	SABKM 22/SSCH/Z	27228.0	66			
M			SABKM 29/D M4	27249.0	64			
MF-SABK/35	17261.0	63	SABKM 29/D M4/Z	27221.0	64			
MF-SABK/35/Z	17978.0	63	SABKM 29/SSCH	27227.0	66			
MF-SABK/SSCH	27218.0	62	SABKM 29/SSCH/Z	27229.0	66			
MF-SABK/SSCH/Z	17979.0	62	SABKM 35/D M4	27256.0	64			
MF/D M4	27217.0	60	SABKM 35/MF/35	27239.0	70			
MF/D M4/Z	17977.0	60	SABKM 65/D M4	27257.0	64			
R			SABKM 65/MF/35	27258.0	70			
RMF/D M4/Z	17986.0	61	SABKMD 1,5-3/SSCH	27250.0	66			
S			SABKMD 1,5-3/SSCH/Z	27259.0	66			
SAB 13,5	1528.0	67	SABKMD 3-12/SSCH	27253.0	66			
SAB 13,5/D	1550.0	65	SABKMD 3-12/SSCH/Z	27255.0	66			
SAB 13,5/F	1572.0	71	SABKMD 3-6/SSCH	27251.0	66			
SAB 13,5/GWP	17357.0	69	SABKMD 3-6/SSCH/Z	27260.0	66			
SAB 13,5/MF/35	17039.0	72	SABKMD 6-8/SSCH	27252.0	66			
SAB 13,5/MF/35/S	17341.0	72	SABKMD 6-8/SSCH/Z	27254.0	66			
SAB 20	1529.0	67	SH 1 BG	2318.2	73			
SAB 20/D	1551.0	65	SH SAB BG	1530.2	73			
SAB 20/F	1573.0	71	SSAB 14	3696.0	68			
SAB 20/GWP	17358.0	69	SSAB 20	3697.0	68			
SAB 20/MF/35	17040.0	72	SSAB 28	3698.0	68			
SAB 20/MF/35/S	17342.0	72	SSAB 35	3699.0	68			
SAB 32/D	17361.0	65	SSAB 5	3694.0	68			
SAB 32/GWP	17359.0	69	SSAB 8	3695.0	68			
SAB 32/MF/35	17363.0	72						
SAB 32/MF/35/S	17343.0	72						
SAB 8	1527.0	67						
SAB 8/D	1549.0	65						
SAB 8/D/M5	1526.0	65						

Types and catalogue numbers, numeric

Cat. no.	Type	Page	Cat. no.	Type	Page	Cat. no.	Type	Page
1			27231.0	SABK 8/MF/35	70	28547.4	KDS-DEG 26-27 BK	43
1526.0	SAB 8/D/M5	65	27232.0	SABK 11/MF/35	70	28548.4	KDS-DEG 27-28 BK	43
1527.0	SAB 8	67	27233.0	SABK 16/MF/35	70	28549.4	KDS-DEG 28-29 BK	43
1528.0	SAB 13,5	67	27234.0	SABK 22/MF/35	70	28550.4	KDS-DEG 29-30 BK	43
1529.0	SAB 20	67	27235.0	SABK 29/MF/35	70	28551.4	KDS-DEG 30-31 BK	43
1530.2	SH SAB BG	73	27236.0	SABK 37/MF/35	70	28552.4	KDS-DEG 31-32 BK	43
1549.0	SAB 8/D	65	27237.0	SABKM 12/MF/35	70	28553.4	KDS-DE/K 2-11 BK	43
1550.0	SAB 13,5/D	65	27238.0	SABKM 18/MF/35	70	28554.4	KDS-DEG/K 7-24 BK	43
1551.0	SAB 20/D	65	27239.0	SABKM 35/MF/35	70	28555.4	KDS-DE 2X4-5 BK	43
1571.0	SAB 8/F	71	27240.0	SABK 3/MF/35/Z	70	28556.4	KDS-DE 2X5-6 BK	43
1572.0	SAB 13,5/F	71	27241.0	SABK 6/MF/35/Z	70	28557.4	KDS-DE 4X2-3 BK	43
1573.0	SAB 20/F	71	27242.0	SABK 8/MF/35/Z	70	28558.4	KDS-DE 4X3-4 BK	43
2			27243.0	SABK 11/MF/35/Z	70	28559.4	KDS-DE/1XASI BK	43
2318.2	SH 1 BG	73	27244.0	SABK 16/MF/35/Z	70	28560.4	KDS-DE/2XASI BK	43
3			27245.0	SABK 22/MF/35/Z	70	28561.6	KDS-DE/B GR	42
3694.0	SSAB 5	68	27246.0	SABKM 12/D M4	64	28562.6	KDS-DE 1,5-2 GR	42
3695.0	SSAB 8	68	27247.0	SABKM 18/D M4	64	28563.6	KDS-DE 2-3 GR	42
3696.0	SSAB 14	68	27248.0	SABKM 22/D M4	64	28564.6	KDS-DE 3-4 GR	42
3697.0	SSAB 20	68	27249.0	SABKM 29/D M4	64	28565.6	KDS-DE 4-5 GR	42
3698.0	SSAB 28	68	27250.0	SABKMD 1,5-3/SSCH	66	28566.6	KDS-DE 5-6 GR	42
3699.0	SSAB 35	68	27251.0	SABKMD 3-6/SSCH	66	28567.6	KDS-DE 6-7 GR	42
17			27252.0	SABKMD 6-8/SSCH	66	28568.6	KDS-DE 7-8 GR	42
17038.0	SAB 8/MF/35	72	27253.0	SABKMD 3-12/SSCH	66	28569.6	KDS-DE 8-9 GR	42
17039.0	SAB 13,5/MF/35	72	27254.0	SABKMD 6-8/SSCH/Z	66	28570.6	KDS-DE 9-10 GR	42
17040.0	SAB 20/MF/35	72	27255.0	SABKMD 3-12/SSCH/Z	66	28571.6	KDS-DE 10-11 GR	42
17261.0	MF-SABK/35	63	27256.0	SABKM 35/D M4	64	28572.6	KDS-DE 11-12 GR	42
17340.0	SAB 8/MF/35/S	72	27257.0	SABKM 65/D M4	64	28573.6	KDS-DE 12-13 GR	42
17341.0	SAB 13,5/MF/35/S	72	27258.0	SABKM 65/MF/35	70	28574.6	KDS-DE 13-14 GR	42
17342.0	SAB 20/MF/35/S	72	27259.0	SABKMD 1,5-3/SSCH/Z	66	28575.6	KDS-DEG/B GR	42
17343.0	SAB 32/MF/35/S	72	27260.0	SABKMD 3-6/SSCH/Z	66	28576.6	KDS-DEG 14-15 GR	42
17356.0	SAB 8/GWP	69	28			28577.6	KDS-DEG 15-16 GR	42
17357.0	SAB 13,5/GWP	69	28500.4	KDS-SR 6/10 BK	24	28578.6	KDS-DEG 16-17 GR	42
17358.0	SAB 20/GWP	69	28501.4	KDS-IVR 6/10 BK	24	28579.6	KDS-DEG 17-18 GR	42
17359.0	SAB 32/GWP	69	28502.4	KDS-SR 8/16 BK	24	28580.6	KDS-DEG 18-19 GR	42
17361.0	SAB 32/D	65	28503.4	KDS-IVR 8/16 BK	24	28581.6	KDS-DEG 19-20 GR	42
17363.0	SAB 32/MF/35	72	28504.4	KDS-SR 10/24 BK	24	28582.6	KDS-DEG 20-21 GR	42
17970.0	SABK 3	58	28504.4	KDS-SR 10/24 BK	24	28583.6	KDS-DEG 21-22 GR	42
17971.0	SABK 6	58	28505.4	KDS-IVR 10/24 BK	24	28584.6	KDS-DEG 22-23 GR	42
17972.0	SABK 8	58	28506.4	KDS-SR 1-4 BK	24	28585.6	KDS-DEG 23-24 GR	42
17973.0	SABK 11	58	28507.4	KDS-IVR 1-4 BK	24	28586.6	KDS-DEG 24-25 GR	42
17974.0	SABK 16	58	28516.4	KDS-Inlay 1 BK	24	28587.6	KDS-DEG 25-26 GR	42
17975.0	SABKM 12	59	28517.4	KDS-Inlay 2 BK	24	28588.6	KDS-DEG 26-27 GR	42
17976.0	SABKM 18	59	28518.4	KDS-Inlay 4 BK	24	28589.6	KDS-DEG 27-28 GR	42
17977.0	MF/D M4/Z	60	28519.4	KDS-Inlay 6 BK	24	28590.6	KDS-DEG 28-29 GR	42
17978.0	MF-SABK/35/Z	63	28520.4	KDS-DE/B BK	43	28591.6	KDS-DEG 29-30 GR	42
17979.0	MF-SABK/SSCH/Z	62	28521.4	KDS-DE 1,5-2 BK	43	28592.6	KDS-DEG 30-31 GR	42
17980.0	SABKM 12/MF/35/Z	70	28522.4	KDS-DE 2-3 BK	43	28593.6	KDS-DEG 31-32 GR	42
17981.0	SABKM 18/MF/35/Z	70	28523.4	KDS-DE 3-4 BK	43	28594.6	KDS-DEG 32-33 GR	42
17982.0	SABKM 12/SSCH/Z	66	28524.4	KDS-DE 4-5 BK	43	28595.6	KDS-DE 2X4-5 GR	42
17983.0	SABKM 18/SSCH/Z	66	28525.4	KDS-DE 5-6 BK	43	28596.6	KDS-DE 2X5-6 GR	42
17984.0	SABKM 12/D M4/Z	64	28526.4	KDS-DE 6-7 BK	43	28597.6	KDS-DE 4X2-3 GR	42
17985.0	SABKM 18/D M4/Z	64	28527.4	KDS-DE 7-8 BK	43	28598.6	KDS-DE 4X3-4 GR	42
17986.0	RMF/D M4/Z	61	28528.4	KDS-DE 8-9 BK	43	28599.6	KDS-DE/1XASI GR	42
27			28529.4	KDS-DE 9-10 BK	43	28600.6	KDS-DE/2XASI GR	42
27217.0	MF/D M4	60	28530.4	KDS-DE 10-11 BK	43	28601.4	KDS-DEG 32-33 BK	43
27218.0	MF-SABK/SSCH	62	28531.4	KDS-DE 11-12 BK	43	28602.4	KDS-Set 1-4 BK	24
27220.0	SABKM 22/D M4/Z	64	28532.4	KDS-DE 12-13 BK	43	28603.4	KDS-Set 6/10 BK	24
27221.0	SABKM 29/D M4/Z	64	28533.4	KDS-DE 13-14 BK	43	28604.4	KDS-Set 8/16 BK	24
27224.0	SABKM 12/SSCH	66	28534.4	KDS-DEG/B BK	43	28605.4	KDS-Set 10/24 BK	24
27225.0	SABKM 18/SSCH	66	28535.4	KDS-DEG 14-15 BK	43	28606.6	KDS-DE 4x4,5 GR	42
27226.0	SABKM 22/SSCH	66	28536.4	KDS-DEG 15-16 BK	43	28607.6	KDS-DE 2x6,5 GR	42
27227.0	SABKM 29/SSCH	66	28537.4	KDS-DEG 16-17 BK	43	28608.4	KDS-DE 14-15 BK	43
27228.0	SABKM 22/SSCH/Z	66	28538.4	KDS-DEG 17-18 BK	43	28609.6	KDS-DE 14-15 GR	42
27229.0	SABK 3/MF/35	70	28539.4	KDS-DEG 18-19 BK	43	28610.4	KDS-KV M20 BK	38
27229.0	SABKM 29/SSCH/Z	66	28540.4	KDS-DEG 19-20 BK	43	28611.4	KDS-KV M25 BK	38
27230.0	SABK 6/MF/35	70	28541.4	KDS-DEG 20-21 BK	43	28612.4	KDS-KV M32 BK	38
			28542.4	KDS-DEG 21-22 BK	43	28613.4	KDS-KV M40 BK	39
			28543.4	KDS-DEG 22-23 BK	43	28614.4	KDS-KV M50 BK	39
			28544.4	KDS-DEG 23-24 BK	43	28615.4	KDS-KV M63 BK	39
			28545.4	KDS-DEG 24-25 BK	43	28616.4	KDS-GM 20 BK	38
			28546.4	KDS-DEG 25-26 BK	43	28617.4	KDS-GM 25 BK	38

Cat. no.	Type	Page	Cat. no.	Type	Page	Cat. no.	Type	Page
28618.4	KDS-GM 32 BK	38	28686.0	BL-VA KDS-SR 10/24	55			
28619.4	KDS-GM 40 BK	39	28687.4	KDS-DE 3x5-6 BK	43			
28620.4	KDS-GM 50 BK	39	28688.6	KDS-DE 3x5-6 GR	42			
28621.4	KDS-GM 63 BK	39	28689.4	KDS-DE 2x7 BK	43			
28622.0	KDS BW 1	40	28690.6	KDS-DE 2x7 GR	42			
28623.0	KDS-EMV-SAB 1-4	41	28691.4	KDS-DE 2x8 BK	43			
28624.0	KDS-EMV-SAB 6/10	41	28692.6	KDS-DE 2x8 GR	42			
28625.0	KDS-EMV-SAB 8/16	41	28700.4	KDS-SR-FB1/A BK	12			
28626.0	KDS-EMV-SAB 10/24	41	28701.4	KDS-SR-FB2/A BK	12			
28630.4	KES 13/24 BK	48	28702.4	KDS-SR-FB2/B BK	12			
28630.6	KES 13/24 GR	48	28703.4	KDS-SR-FB3/A BK	13			
28631.4	KES 14/24 BK	48	28704.4	KDS-SR-FB3/B BK	13			
28631.6	KES 14/24 GR	48	28705.4	KDS-SR-FB3/C BK	13			
28632.4	KES 16/24 BK	48	28706.4	KDS-SR-FB3/D BK	13			
28632.6	KES 16/24 GR	48	28707.4	KDS-SR-FB4/A BK	12			
28633.4	KES 16-1/24 BK	49	28708.4	KDS-SR-FB4/B BK	12			
28633.6	KES 16-1/24 GR	49	28709.4	KDS-SR-FB4/C BK	12			
28634.4	KES 17/24 BK	49	28710.4	KDS-SR-FB4/D BK	13			
28634.6	KES 17/24 GR	49	28711.4	KDS-SR-FB4/E BK	13			
28635.4	KES 20/24 BK	49	28712.4	KDS-SR-FB4/F BK	13			
28635.6	KES 20/24 GR	49	28713.6	KDS-DE-FB1/A GR	16			
28636.4	KES 21/24 BK	49	28714.6	KDS-DE-FB1/B GR	16			
28636.6	KES 21/24 GR	49	28715.6	KDS-DE-FB1/C GR	16			
28637.4	KES 32/24 BK	49	28716.6	KDS-DE-FB1/D GR	16			
28637.6	KES 32/24 GR	49	28717.6	KDS-DE-FB1/E GR	16			
28640.4	KES-GB 13/24 BK	48	28718.6	KDS-DE-FB1/F GR	16			
28640.6	KES-GB 13/24 GR	48	28719.6	KDS-DE-FB2/A GR	16			
28641.4	KES-GB 14/24 BK	48	28720.6	KDS-DE-FB2/B GR	16			
28641.6	KES-GB 14/24 GR	48	28721.6	KDS-DE-FB2/C GR	16			
28642.4	KES-GB 16/24 BK	48	28722.6	KDS-DE-FB2/D GR	16			
28642.6	KES-GB 16/24 GR	48	28723.6	KDS-DE-FB2/E GR	16			
28643.4	KES-GB 16-1/24 BK	49	28724.6	KDS-DE-FB2/F GR	16			
28643.6	KES-GB 16-1/24 GR	49	28725.6	KDS-DE-FB3/A GR	16			
28644.4	KES-GB 17/24 BK	49	28726.6	KDS-DE-FB3/B GR	16			
28644.6	KES-GB 17/24 GR	49	28727.6	KDS-DE-FB4/A GR	16			
28645.4	KES-GB 20/24 BK	49	28728.6	KDS-DE-FB4/B GR	16			
28645.6	KES-GB 20/24 GR	49	28729.0	BL-VA KDS-FB1	55			
28646.4	KES-GB 21/24 BK	49	28734.0	BL KDS-FB1	55			
28646.6	KES-GB 21/24 GR	49	28735.0	BL KDS-FB2	55			
28647.4	KES-GB 32/24 BK	49	28736.0	BL KDS-FB3	55			
28647.6	KES-GB 32/24 GR	49	28737.0	BL KDS-FB4	55			
28650.4	KES-R 13/24 BK	48	28741.0	BL-VA KDS-FB2	55			
28650.6	KES-R 13/24 GR	48	28742.0	BL-VA KDS-FB3	55			
28651.4	KES-R 14/24 BK	48	28743.0	BL-VA KDS-FB4	55			
28651.6	KES-R 14/24 GR	48	28744.0	BL KES	54			
28652.4	KES-R 16/24 BK	48	28745.0	BL KDS-FP2	54			
28652.6	KES-R 16/24 GR	48	28746.0	BL KDS-KV M20	54			
28653.4	KES-R 16-1/24 BK	49	28747.0	BL KDS-KV M25	55			
28653.6	KES-R 16-1/24 GR	49	28748.0	BL KDS-KV M32	55			
28654.4	KES-R 17/24 BK	49	28749.0	BL KDS-KV M40	55			
28654.6	KES-R 17/24 GR	49	28750.0	BL KDS-KV M50	55			
28655.4	KES-R 20/24 BK	49	28751.0	BL KDS-KV M63	55			
28655.6	KES-R 20/24 GR	49	28752.0	BL-VA KES	54			
28656.4	KES-R 21/24 BK	49	28753.0	BL-VA KDS-FP2	54			
28656.6	KES-R 21/24 GR	49	28754.0	BL-VA KDS-KV M20	54			
28657.4	KES-R 32/24 BK	49	28755.0	BL-VA KDS-KV M25	55			
28657.6	KES-R 32/24 GR	49	28756.0	BL-VA KDS-KV M32	55			
28660.4	KDS-FP 2x10/24 BK	30	28757.0	BL-VA KDS-KV M40	55			
28661.4	KDS-FP 3x10/24 BK	30	28758.0	BL-VA KDS-KV M50	55			
28664.3	KDS-FP-IVR OG	30	28759.0	BL-VA KDS-KV M63	55			
28670.4	KDS-DE 15-16 BK	43	28762.6	KDS-DE 4x6 GR	42			
28671.6	KDS-DE 15-16 GR	42	28763.4	KDS-DE 4x6 BK	43			
28672.4	KDS-DE 4X5 BK	43						
28673.6	KDS-DE 4X5 GR	42						
28674.0	BL KDS-SR 1-4	54						
28675.0	BL KDS-SR 6/10	54						
28676.0	BL KDS-SR 8/16	54						
28677.0	BL KDS-SR 10/24	55						
28679.0	Hydraulic hand pump for sheet-metal punch	53						
28681.4	KDS-DE 4x4,5 BK	43						
28682.4	KDS-DE 2x6,5 BK	43						
28683.0	BL-VA KDS-SR 1-4	54						
28684.0	BL-VA KDS-SR 6/10	54						
28685.0	BL-VA KDS-SR 8/16	54						

Otto-Hahn-Str. 7
D-33161 Hövelhof,
Germany

Phone +49 (0) 5257 9833-0 info@conta-clip.com
Fax +49 (0) 5257 9833-33 www.conta-clip.com



Our products for your challenges:

01 CONTA-CONNECT
Terminal blocks with Push-in
connection system

Cat. no. 98070.2

02 CONTA-CONNECT
Terminal blocks with screw connection
system and special terminals

Cat. no. 98071.2

03 CONTA-CONNECT
Terminal blocks with tension-spring
connection system

Cat. no. 98072.2

04 CONTA-CONNECT
Installation materials and other accessories
for terminal blocks

Cat. no. 98073.2

05 CONTA-LABEL
Marking components
for thermal transfer marking systems

Cat. no. 98074.2

06 CONTA-LABEL
Marking components
for ink-based marking systems

Cat. no. 98075.2

07 CONTA-BOX
Housings

Cat. no. 98076.2

08 Cable management systems
KDS cable entries,
KES cable entries,
SAB/SSAB/SABK shielding solutions

Cat. no. 98077.2

09 CONTA-ELECTRONICS
Electrical and electronic cabinet components

Cat. no. 98078.2

10 CONTA-CON
PCB terminals and connectors

Cat. no. 98079.2